

brother

PARTS BOOK

LK3-B435

P435102

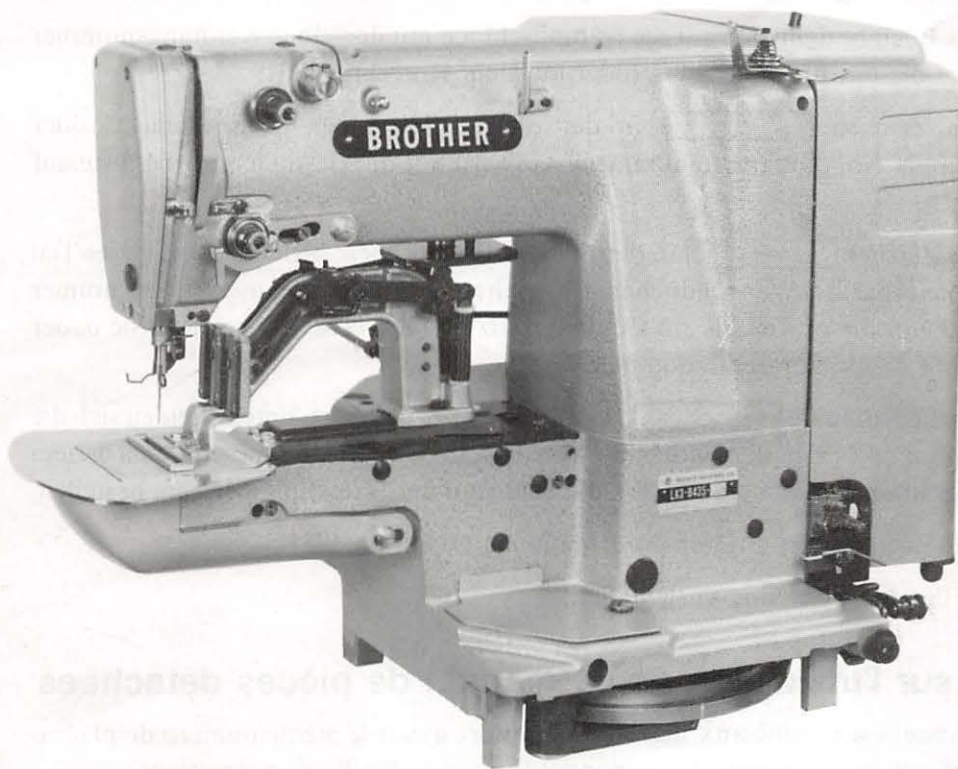



High Speed Lock Stitch Pattern Tacking Machine
(With a Two-Step Presser Device)

BROTHER INDUSTRIES, LTD.

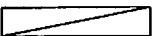

NAGOYA, JAPAN

From the library of: Superior Sewing Machine & Supply LLC



Notes for using this parts book

1. This book is applicable to sewing machines which have the same plate number as shown on the cover of this book (or correction sheet).
2. If the symbol  is found in the "Parts No." column or the "Assembly No." column, refer to the different parts list on page 15.
3. The symbol  in the "Parts No." column indicates that the parts is not available for supply. If, however, there is a number in the "Assembly No." column, the parts can be ordered as an assembly. Please, therefore, order by using the Assembly No.
4. Those parts whose parts No. columns show  are different according to number of stitches and design.
Therefore, order the parts by using the design number and the part name stamped on the model plate.
5. This book was prepared based on information available in July, 1981.
6. Parts are subject to changes in design without prior notice.



Anmerkungen zum Gebrauch dieses Stücklistebuches

1. Dieses Buch bezieht sich auf die Nähmaschinen mit derselben Kennungsnummer wie auf diesem Buchumschlag (oder auf dem Korrekturblatt).
2. Dieses Zeichen  in der Spalte "Parts No. (Teilnummer)" oder "Assembly No. (Gerätesatznummer)" verweist auf die Gesonderte Stückliste auf Seite 15.
3. Dieses Zeichen  in der Spalte "Teilnummer" bedeutet, daß dieser Teil nicht lieferbar ist. Wenn jedoch in der Spalte "Gerätesatznummer" eine Nummer steht, kann dieser Teil als ein Geräteteilsatz bestellt werden. Bestellen Sie daher bitte mit dieser Gerätesatznummer.
4. Wenn die Kolumne  für die Zubehöre blank ist, unterscheiden sich die Zubehöre in Zahlen der Nadel und Mustern, so daß bitte die Zubehöre nach dem Musternummer und dem Artikel, die beide auf der Namenplate liegen, bestellen.
5. Dieses Buch basiert auf den Informationen vom Juli, 1981.
6. Modelländerungen sind vorbehalten.

Notes sur l'utilisation de ce manuel de pièces détachées

1. Ce manuel est destiné aux machines à coudre ayant le même numéro de plaque montré sur la couverture de ce manuel (ou sur la feuille de corrections).
2. Si le symbole  se trouve dans la colonne "Parts No. (N° de pièce)" ou dans la colonne "Assembly No. (N° jeu de pces)", veuillez vous référer à la liste de pièces annexe page 15.
3. Le symbole  dans la colonne "N° de pièce" signifie que la pièce ne peut être fournie. Si, dans la colonne "N° jeu de pces", il y a un numéro de nomenclature, la pièce peut être commandée comme faisant partie d'un jeu de pièces. Donc, pour toute commande, veuillez spécifier le N° de jeu de pièces.
4. Le symbole  dans la colonne "N° de pièce" signifie que la pièce peut être commandée par le nom de pièce et la numéro de dessins marquant dans la plaque des données, parce que la pièce-ci est différente par le dessin et le nombre d'aiguille.
5. Ce manuel a été fait d'après les renseignements valables au mois de Juillet 1981.
6. Les pièces peuvent être sujettes à des modifications sans préavis.

Notas para usar este Libro de Piezas

1. Este libro sirve para todas las máquinas de coser que llevan la misma placa de identificación que la que se puede ver en la tapa de este libro (o en la hoja de erratas).
2. De haber un símbolo  junto al "Parts No. (Número de Pieza)" o en la columna del "Assembly No. (Número de Juego)", habrá que mirar la lista de piezas separada de la página 15.
3. El símbolo , que se encuentra en la columna del "Número de Pieza", quiere decir que no se dispone de dicha pieza sola. Cuando, empero, hay un número en la columna del "Numero de Juego", se podrá ordenar la pieza con todo el juego. Por lo tanto, será mejor hacer el pedido recurriendo al número del juego respectivo.
4. El símbolo , que se encuentra en la columna del "Número de pieza", quiere decir que esa pieza difiere según el número de puntada y el patrón. Por lo tanto, ordene una pieza con su nombre y el nombre del patrón que se halla en la placa de modelo.
5. Este libro ha sido compilado basándose en los datos de que se disponía en julio de 1981.
6. Las piezas quedan sujetas a cambios de diseño sin aviso previo.

CONTENTS

A. Machine Body	1
B. Upper Shaft · Lower Shaft and Needle Bar Mechanism	2
C. Pulley and Clutch Mechanism	3
D. Power Lift and Clutch Mechanism	4
E. Presser Arm Mechanism	5
F. Feed Mechanism	6
G. Vertical Shaft Mechanism	7
H. Work Clamp and Thread Wiper Mechanism	8
J. Thread Trimming and Thread Nipper Mechanism	9
K. Bobbin Winder and Threading Mechanism	10
L. Oil Pan	11
M. Lubrication	12
N. Two-Step Presser Mechanism	13
Z. Accessories	14
DIFFERENT PARTS LIST	15
INDEX	21

A. Machine Body

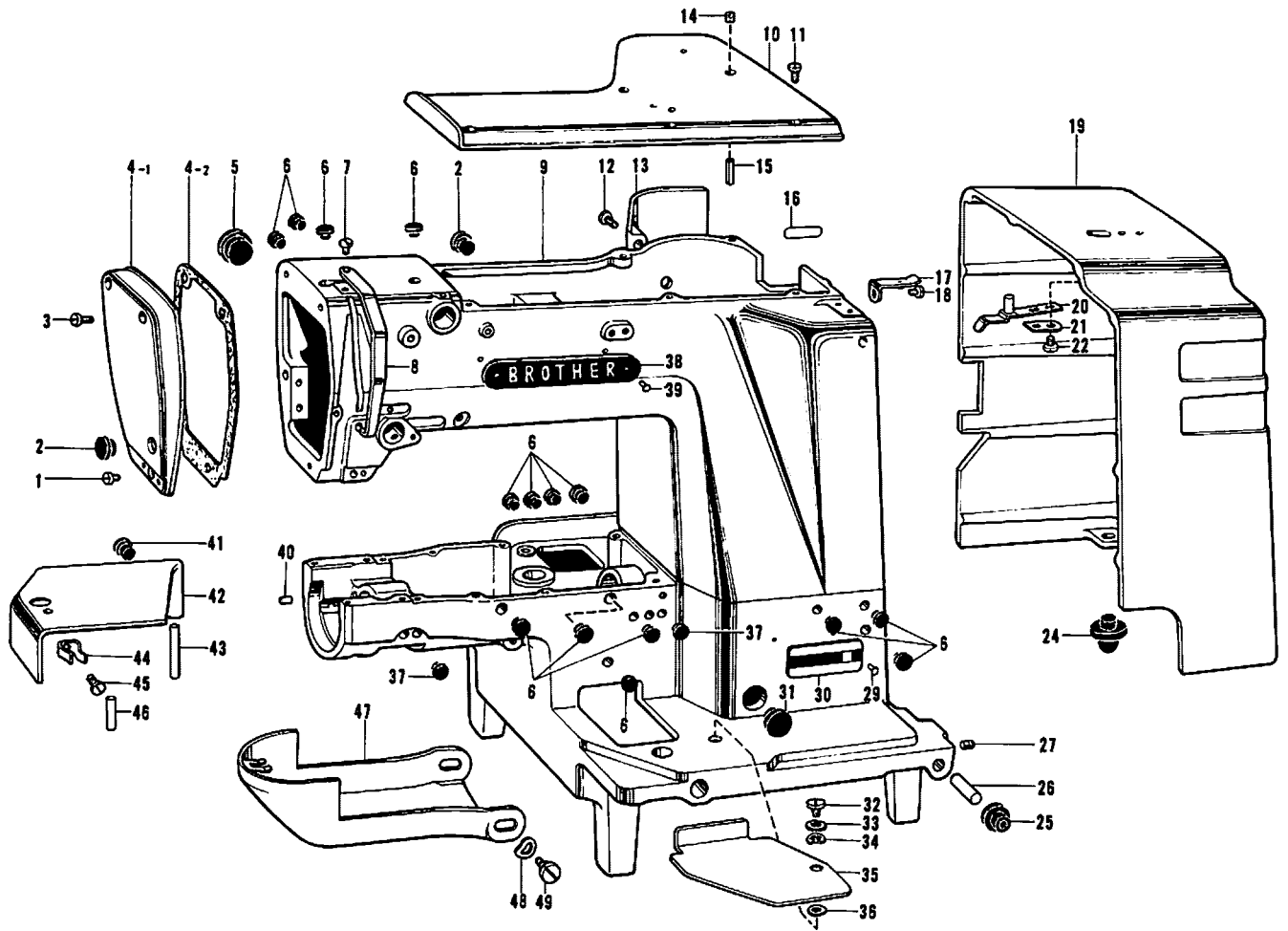

Ref. No.	Name of Parts	Q'ty	Parts No.	Assembly No.	Ref. No.	Name of Parts	Q'ty	Parts No.	Assembly No.
A-1	Screw 4.76 x 7	1	009710-7-12		A-25	Head Cushion	2	152868-0-00	
A-2	Oil Cap	2	117934-0-01		A-26	Hinge Shaft	2	152867-0-00	
A-3	Screw 4.76 x 14	2	009711-4-12		A-27	Screw 5.95	2	151604-0-02	
A-4-1	Face Plate	1	152832-0-02	A-4 Face Plate Assembly 152831-0-00	A-29	Pin	2		
A-4-2	Packing	1	152833-0-01		A-30	Model Plate	1		
A-5	Oil Cap	1	140392-0-01		A-31	Oil Cap	1	108520-0-01	
A-6	Oil Cap	15	117936-0-01		A-32	Screw 6.35	1	145480-0-01	
A-7	Screw 3.57 x 8	1	009670-8-12		A-33	Washer	1	118719-0-01	
A-8	Thread Take-up Cover	1	152841-0-02		A-34	Washer	1	100315-0-02	
A-9	Arm Bed	1			A-35	Bed Cover (R)	1	152835-0-02	
A-10	Top Cover	1	152830-0-02		A-36	Washer 6.35	1	025770-2-32	
A-11	Screw 5.95 x 14	6	009761-4-12		A-37	Oil Cap	2	104450-0-01	
A-12	Screw 4.76 x 14	4	009711-4-12		A-38	Name Plate	2		
A-13	Side Cover	1	152834-0-02		A-39	Pin	4		
A-14	Felt	2	154785-0-00		A-40	Pin	1	141808-0-01	
A-15	Spring Pin AW5	2	047501-2-42		A-41	Oil Cap	1	104450-0-01	
A-16	Parts Book Number Plate	1			A-42	Bed Cover (L) Assembly	1		
A-17	Belt Cover Spring Plate	1	152989-0-01		A-43	Bed Cover Shaft	1	152839-0-01	
A-18	Screw 4.37 x 8	1	009680-8-12		A-44	Bed Cover Stop Spring	1	114985-0-01	
A-19	Belt Cover (A)	1	153960-0-02		A-45	Screw 4.37 x 6	1	009680-6-12	
A-20	Belt Cover Spring	1	152848-0-01		A-46	Grooved Pin	1	152838-0-01	
A-21	Belt Cover Stopper	1	152986-0-01		A-47	Shuttle Race Cover Assembly	1	152842-0-02	
A-22	Screw 4.37 x 8	2	009680-8-12		A-48	Washer	2	109239-0-02	
A-24	Packing	2	152847-0-00		A-49	Screw 5.95	2	115493-0-02	

B. Upper Shaft · Lower Shaft and Needle Bar Mechanism

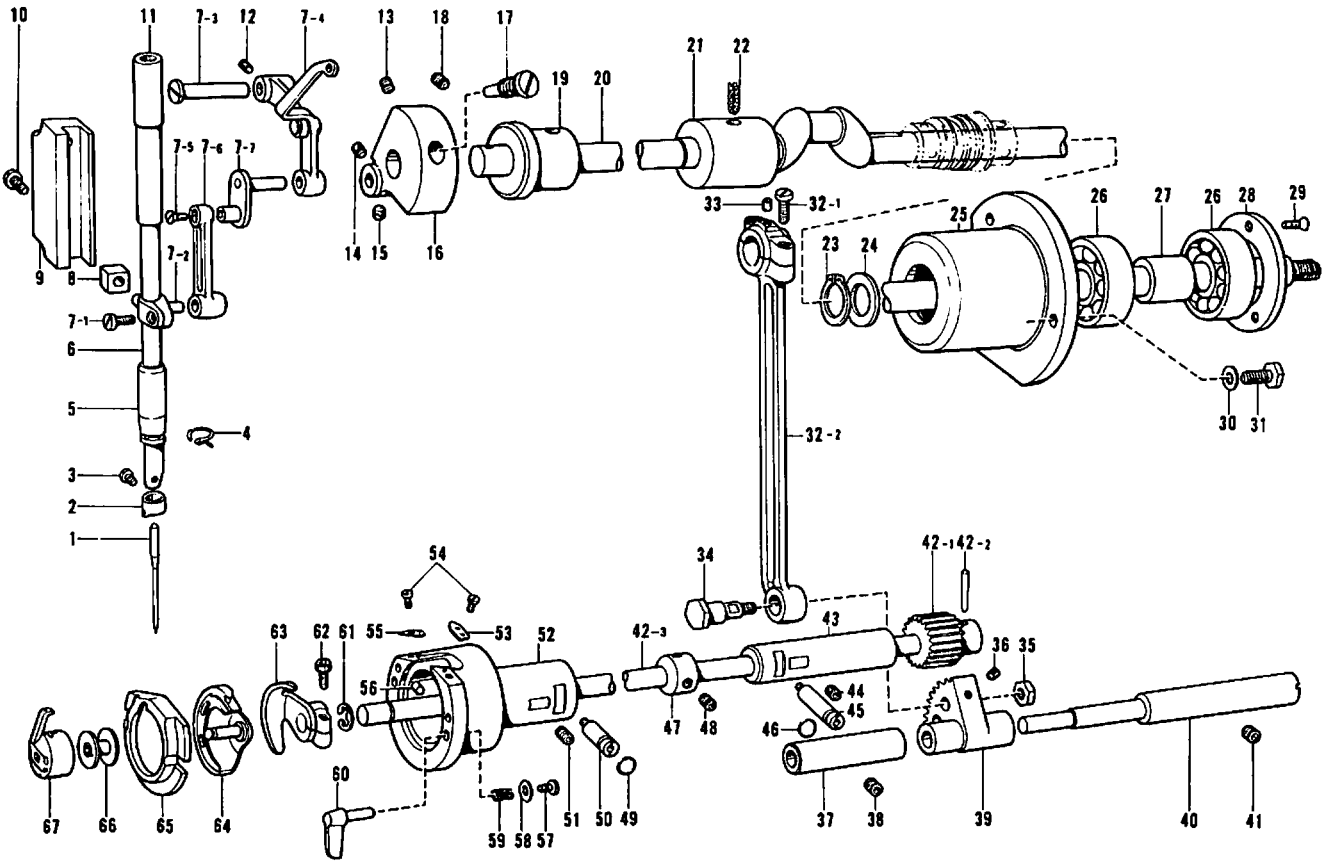

Ref. No.	Name of Parts	Q'ty	Parts No.	Assembly No.	Ref. No.	Name of Parts	Q'ty	Parts No.	Assembly No.
B-1	Needle	1			B-33	Felt	1	107149-0-01	
B-2	Needle Bar Thread Guide	1			B-34	Screw	1	141786-0-01	
B-3	Screw 3.57	1	144458-0-01		B-35	Nut 7.14	1	104689-0-01	
B-4	Thread Guide (D)	1	152891-0-01		B-36	Screw 4.37 x 6	1	014680-6-22	
B-5	Needle Bar Bushing (D)	1	152243-0-01		B-37	Rock Shaft Bushing	1	152247-0-01	
B-6	Needle Bar	1			B-38	Screw 5.95 x 6	1	014760-6-22	
B-7-1	Screw 4.37 x 8	1	009680-8-12	B-7 Thread Take-up Lever Assembly 152232-0-01	B-39	Rock Gear	1	152245-0-01	
B-7-2	Needle Bar Clamp	1	152239-0-01		B-40	Rock Gear Shaft	1	152246-0-01	
B-7-3	Stud	1	152236-0-01		B-41	Screw 5.95 x 6	1	014760-6-22	
B-7-4	Thread Take-up Assembly	1	153330-0-01		B-42-1	Lower Shaft Gear	1		B-42 Lower Shaft Assembly 152191-0-01
B-7-5	Screw 3.57L	1	100253-0-01		B-42-2	Taper Pin 3 x 16	1	046301-6-20	
B-7-6	Needle Bar Connector	1	152238-0-01		B-42-3	Lower Shaft	1		
B-7-7	Needle Bar Crank	1	152237-0-01		B-43	Lower Shaft Bushing	1	152250-0-01	
B-8	Slide Block	1	142211-0-01	B-44	Screw 5.95 x 6	1	014760-6-22		
B-9	Needle Bar Guide	1	152244-0-00	B-45	Driver Adjusting Stud	1	152676-0-01		
B-10	Screw 6.35 x 14	2	009781-4-12	B-46	Packing PW3	1	081003-6-70		
B-11	Needle Bar Bushing (U)	1	152242-0-01	B-47	Collar	1	110495-0-03		
B-12	Screw 5.95	1	013761-4-12	B-48	Screw 6.35 x 6	2	014770-6-22		
B-13	Screw 6.35 x 6	1	014770-6-22	B-49	Packing PW3	1	081003-6-70		
B-14	Screw 6.35 x 6	1	014770-6-22	B-50	Shuttle Hook Adjusting Stud	1	152678-0-01		
B-15	Screw 6.35	1	101706-0-01	B-51	Screw 5.95 x 6	1	014760-6-22		
B-16	Counter Weight	1	152231-0-00	B-52	Shuttle Race Body	1	152677-0-01		
B-17	Screw 7.14	1	100250-0-01	B-53	Shuttle Race Thread Guide (R)	1	152679-0-01		
B-18	Screw 5.95	1	013761-4-12	B-54	Screw 3.18 x 3	2	009660-3-12		
B-19	Upper Shaft Bushing (Front)	1	152000-0-01	B-55	Shuttle Race Thread Guide (L)	1	152680-0-01		
B-20	Upper Shaft	1	151995-0-01	B-56	Felt	2	153050-0-00		
B-21	Upper Shaft Bushing (Intermediate)	1	140726-0-00	B-57	Screw 3.18 x 7	2	009660-7-12		
B-22	Wick 4 x 4	1	153925-0-01	B-58	Washer 3.2	2	402887-0-01		
B-23	Stop Ring C15	1	048150-1-42	B-59	Spring	2	152684-0-01		
B-24	Thrust Ring	1	116920-0-01	B-60	Shuttle Race Ring Set Claw	2	152683-0-01		
B-25	Ball Bearing Case	1	151997-0-00	B-61	Stop Ring E8	1	048080-3-42		
B-26	Ball Bearing 6302VV	2	072630-2-60	B-62	Bolt 5 x 14	1	018501-4-22		
B-27	Bearing Collar	1	151998-0-00	B-63	Driver	1	152681-1-01		
B-28	Bearing Cap	1	151999-0-01	B-64	Shuttle Hook	1			
B-29	Screw 3.57	3	102843-0-04	B-65	Shuttle Race Ring	1			
B-30	Washer 6	3	025060-2-32	B-66	Bobbin	1			
B-31	Bolt 5.95 x 14	3	017761-4-12	B-67	Bobbin Case Assembly	1			
B-32-1	Screw 4.76	2	144712-0-02						
B-32-2	Crank Rod	1		B-32 Crank Rod Assembly 153040-0-01					

C. Pulley and Clutch Mechanism

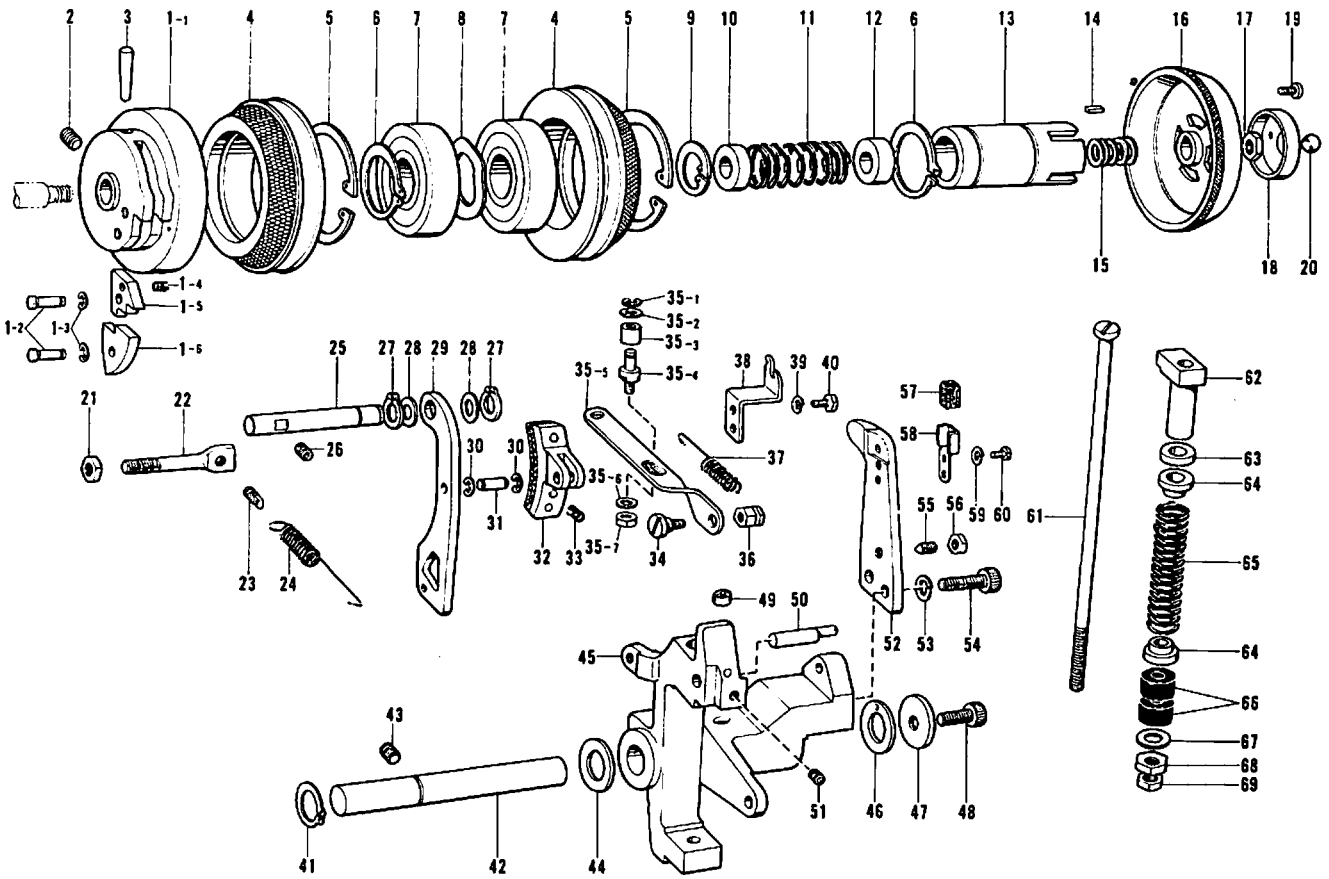

Ref. No.	Name of Parts	Q'ty	Parts No.	Assembly No.	Ref. No.	Name of Parts	Q'ty	Parts No.	Assembly No.
C-1-1	Stop Cam Assembly	1		C-1 Stop Cam Assembly 153044-0-01	C-35-2	Washer	1	113431-0-02	C-35 Clutch Lever Rod Assembly 151904-1-01
C-1-2	Pin	2	153058-0-01		C-35-3	Roller	1	107744-0-01	
C-1-3	Stop Ring E4	2	048040-3-42		C-35-4	Roller Stud	1	151906-1-01	
C-1-4	Brake Cam Segment Spring	1	152694-0-01		C-35-5	Clutch Lever Rod	1	151905-1-01	
C-1-5	Brake Cam Segment	1	152693-0-01		C-35-6	Washer 4.37	1	025680-1-33	
C-1-6	Flange Cam Segment	1	115003-0-01		C-35-7	Nut 4.37	1	021680-2-02	
C-2	Screw 6.35 x 6	1	014770-6-22		C-36	Nut 5.95	1	151908-0-01	
C-3	Taper Pin 6 x 35	1	147111-0-01		C-37	Spring	1	155501-0-01	
C-4	Pulley Assembly	2	152695-0-01		C-38	Spring Hook	2	151910-0-01	
C-5	Stop Ring C62	2	048620-2-42		C-39	Washer 2-5	2	028050-2-42	
C-6	Stop Ring C35	2	048350-1-42	C-40	Bolt 4.76	2	117363-0-01		
C-7	Ball Bearing 6007VV	2	072600-7-60	C-41	Stop Ring C18	1	048180-1-42		
C-8	Washer	1	152699-0-01	C-42	Clutch Lever Shaft	1	151887-0-01		
C-9	Stop Ring C24	1	048240-2-42	C-43	Screw 7.94 x 10	1	014821-0-22		
C-10	Slide Bush (B)	1	151946-0-00	C-44	Washer 18	1	152756-0-01		
C-11	Clutch Spring	1	152701-0-01	C-45	Clutch Lever	1	151886-0-01		
C-12	Slide Bush (A)	1	152700-0-00	C-46	Washer 18	1	151929-0-00		
C-13	Slide Metal	1	152698-0-01	C-47	Washer 8	1	152728-0-01		
C-14	Key 3 x 3 x 6	1	152704-0-00	C-48	Bolt 8 x 15	1	151163-0-01		
C-15	Spacer	5	152703-0-00	C-49	Felt	1	151927-0-01		
C-16	Clutch	1	152702-0-01	C-50	Brake Side Pin	1	151901-0-01		
C-17	Nut 10L	1	152705-0-01	C-51	Screw 5.95 x 6	1	014760-6-22		
C-18	Ball Holder	1	152706-0-01	C-52	Ball Presser Plate	1	151888-1-01		
C-19	Screw 3.18 x 7	4	009660-7-12	C-53	Washer 2-8	2	028080-2-42		
C-20	Steel Ball 3/8	1	071095-2-50	C-54	Bolt 8 x 25	2	018082-5-22		
C-21	Nut 7.94	1	106147-0-01	C-55	Screw 6.35	1	115012-0-02		
C-22	Spring Hook	1	151903-0-01	C-56	Nut 6.35	1	150554-0-02		
C-23	Spring Hook	1	110251-0-01	C-57	Wick	1	152977-0-01		
C-24	Brake Spring	1	151902-0-01	C-58	Wick Holder	1	152976-0-01		
C-25	Brake Lever Shaft	1	151900-0-01	C-59	Washer 2-4	2	028040-2-42		
C-26	Screw 5.95	1	013761-4-10	C-60	Screw 3.57 x 5	2	009670-5-12		
C-27	Stop Ring C11	2	048110-1-42	C-61	Stopper Bar	1	151893-0-01		
C-28	Horizontal Feed Crank Ring	2	142628-0-01	C-62	Clutch Stopper	1	151889-0-01		
C-29	Brake Lever	1	151894-0-01	C-63	Cushion Rubber	1	151890-0-00		
C-30	Stop Ring E4	2	048040-3-42	C-64	Spring Holder	2	151892-0-01		
C-31	Brake Shaft	1	151898-0-01	C-65	Clutch Spring	1	151891-0-01		
C-32	Brake Assembly	1	151895-0-00	C-66	Cushion Rubber	2	115018-0-01		
C-33	Spring	1	151899-0-01	C-67	Washer 7.14	1	025800-3-33		
C-34	Screw 5.95	1	151907-0-01	C-68	Nut 7.14	1	021800-1-03		
C-35-1	Stop Ring E3	1	048030-3-42	C-35 151904-1-01	C-69	Nut 7.14	1	104689-0-01	

D. Power Lift and Clutch Mechanism

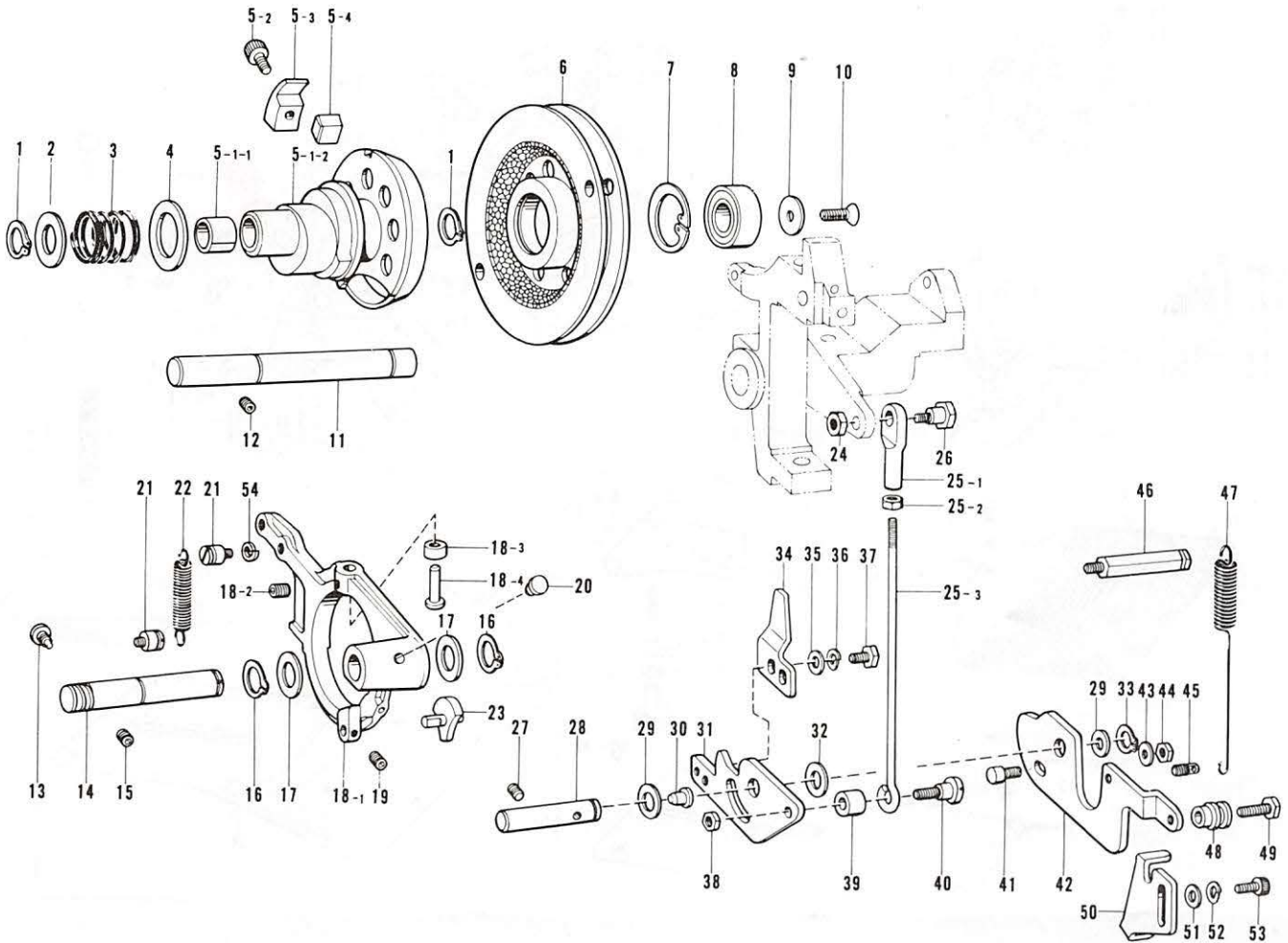

Ref. No.	Name of Parts	Q'ty	Parts No.	Assembly No.	Ref. No.	Name of Parts	Q'ty	Parts No.	Assembly No.
D- 1	Stop Ring C17	2	048170-1-42		D-25-1	Joint	1	154333-0-01	D-25 Connecting Rod Assembly 152808-1-01
D- 2	Washer 17	1	151937-0-01		D-25-2	Nut 6.35	1	150555-0-01	
D- 3	Clutch Spring P	1	151936-0-01		D-25-3	Connecting Rod	1	154332-0-01	
D- 4	Washer	1	151938-0-01		D-26	Screw 6.35	1	151912-0-01	
D- 5-1-1	DV Bush	2	151935-0-00	D-5-1 Power Cam Assembly 151933-0-01	D-27	Screw 5.95	1	013761-4-10	
D- 5-1-2	Power Cam	1			D-28	Starting Lever Shaft	1	151925-0-01	
D- 5-2	Bolt 6 x 8	1	018060-8-22	D-5 Power Cam Set 155523-0-01	D-29	Horizontal Feed Crank Ring	2	142628-0-01	
D- 5-3	Power Cam Stopper (A)	1	151940-0-01		D-30	Cap for Oil Inlet	1	111865-0-01	
D- 5-4	Power Cam Stopper (B) Assembly	1	151941-0-01	D-31	Starting Lever	1	151919-1-01		
D- 6	Pulley	1	153867-1-01	D-32	Washer	1	110505-0-01		
D- 7	Stop Ring C35	1	048350-2-42	D-33	Stop Ring C11	1	048110-1-42		
D- 8	Ball Bearing 6003VV	1	072600-3-60	D-34	Starting Safety Lever	1	151920-0-01		
D- 9	Bearing Cover	1	151932-0-01	D-35	Washer	2	113431-0-02		
D-10	Screw 4.76	1	107231-0-02	D-36	Washer 2-5	2	028050-2-42		
D-11	P Pulley Shaft	1	151928-0-01	D-37	Bolt 4.76 x 14	2	017711-4-12		
D-12	Screw 5.95 x 6	1	014760-6-22	D-38	Nut 6.35	1	150556-0-01		
D-13	Screw	1	151954-0-01	D-39	Collar 13	1	151914-0-01		
D-14	Clutch Actuating Lever Shaft	1	151952-0-01	D-40	Screw 6.35	1	151913-0-01		
D-15	Screw 7.94 x 10	1	014821-0-22	D-41	Screw	1	154155-1-01		
D-16	Stop Ring C16	2	048160-1-42	D-42	Starting Lever Plate	1	155499-0-01		
D-17	Washer 16	2	151953-0-01	D-43	Washer 6	1	025060-2-32		
D-18-1	Clutch Actuating Lever	1		D-44	Nut 5.95	1	150553-0-01		
D-18-2	Screw 5.95 x 6	2	014760-6-22	D-45	Spring Hook	1	110251-0-01		
D-18-3	Roller 11	2	151947-1-01	D-46	Spring Hook	1	151924-0-01		
D-18-4	Roller Stud	2	151948-0-01	D-47	Spring	1	151923-0-01		
D-19	Screw 5.95 x 6	1	014760-6-22	D-48	Chain Hook	1	151922-0-01		
D-20	Cap for Oil Inlet	1	111865-0-01	D-49	Bolt 5.95 x 22	1	017762-2-02		
D-21	Spring Hook	2	141472-0-02	D-50	Starting Lever Stopper	1	155500-0-01		
D-22	Spring	1	151951-0-01	D-51	Washer	2	025060-1-32		
D-23	Roller Stud Assembly	1	151949-0-01	D-52	Washer 2-6	2	028060-2-42		
D-24	Nut 6.35	1	150556-0-01	D-53	Bolt 6 x 16	2	018061-6-22		
				D-54	Washer 2-6	1	028060-2-42		

E. Presser Arm Mechanism

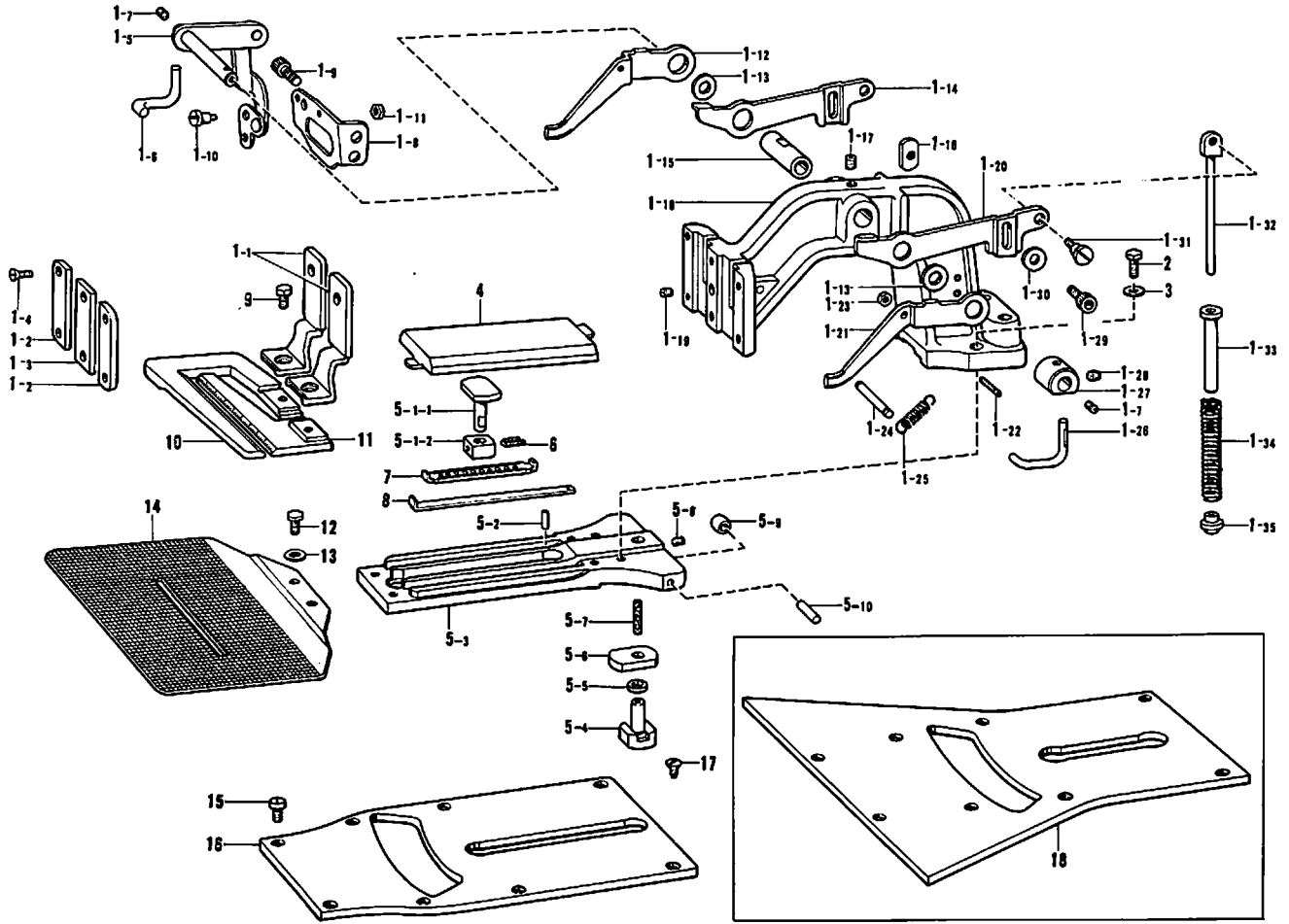

Ref. No.	Name of Parts	Q'ty	Parts No.	Assembly No.	Ref. No.	Name of Parts	Q'ty	Parts No.	Assembly No.
E- 1- 1	Work Clamps	2		E-1 Presser Arm Assembly	E- 1-33	Presser Spring Collar	2	153567-0-00	E-1 Presser Arm Assembly
E- 1- 2	Work Clamp Guide Bracket (A)	2	153369-0-01		E- 1-34	Presser Spring	2		
E- 1- 3	Work Clamp Guide Bracket (B)	1	153370-0-01		E- 1-35	Presser Spring Washer	2	152788-0-00	
E- 1- 4	Screw 3.57	6	107038-0-03		E- 2	Bolt 5.95 x 14	2	017761-4-12	
E- 1- 5	Work Clamp Lifter Plate Assembly	1	153948-0-01		E- 3	Washer 6	2	025060-2-32	
E- 1- 6	Work Clamp Rod (L)	1	153954-0-01		E- 4	Feed Guide Cover	1		
E- 1- 7	Screw 4.37 x 6	2	014680-6-22		E- 5- 1-1	Tack Regulator Shaft	1		E-5-1 Tack Regulator Assembly 153380-0-01
E- 1- 8	Work Clamp Lifter Lever Holder	1	153953-0-01		E- 5- 1-2	Slide Block	1		
E- 1- 9	Bolt M5 x 12	2	018501-2-22		E- 5- 2	Roller	2	148133-0-01	
E- 1-10	Roller Stud	1	110168-0-01		E- 5- 3	Feed Guide	1		
E- 1-11	Nut 4.37	1	021680-2-02		E- 5- 4	Tack Width Regulator Assembly	1	156108-0-01	
E- 1-12	Presser Arm Lever ALS	1	153945-0-01		E- 5- 5	Washer	1	156109-0-01	E-5 Feed Guide Assembly 156075-0-01
E- 1-13	Thrust Ring	2	143591-0-01		E- 5- 6	Slide Block	1	156077-0-01	
E- 1-14	Presser Arm Lever BL	1	153962-0-01		E- 5- 7	Felt	1	156080-0-00	
E- 1-15	Lever Shaft Bushing	1	153944-0-01		E- 5- 8	Screw 5.95 x 6	1	014760-6-22	
E- 1-16	Presser Arm Lever Plate	2	153571-0-01		E- 5- 9	Roller	2		
E- 1-17	Screw 5.95 x 6	1	014760-6-22		E- 5-10	Pin A3 x 17.8	2		
E- 1-18	Presser Arm	1	153364-0-02		E- 6	Wick	1	153926-0-01	
E- 1-19	Screw 4.37 x 6	1	014680-6-22		E- 7	Slide Plate	2	153384-0-01	
E- 1-20	Presser Arm Lever BR	1	153947-0-01		E- 8	Washer	2	153383-0-01	
E- 1-21	Presser Arm Lever AR5	1	153946-0-01		E- 9	Bolt 4.37	2		
E- 1-22	Spring Hook	2	110251-0-01		E-10	Work Clamp Presser (L)	1	*	
E- 1-23	Nut 3.57	2	021670-1-02		E-11	Work Clamp Presser (R)	1	*	
E- 1-24	Spring Hook Pin	1	153957-0-01		E-12	Bolt 4.37 x 5	2	017680-5-12	
E- 1-25	Spring	2	153961-0-01		E-13	Washer 4.37	2	025680-2-32	
E- 1-26	Presser Rod (R)	1	153955-0-01		E-14	Feed Plate	1	*	
E- 1-27	Collar	1	153956-0-01		E-15	Screw 4.37	6	.45318-0-01	
E- 1-28	Screw 6.35	1	101706-0-01		E-16	Feed Guide Plate 100	1		
E- 1-29	Bolt 5 x 8	2	018500-8-22		E-17	Screw 4.37	2	100032-0-04	
E- 1-30	Washer	2	140407-0-02		E-18	Feed Guide Plate 140	1		
E- 1-31	Screw 4.76	2	145478-0-01						
E- 1-32	Presser Spring Guide Rod	2	153570-0-01						

F. Feed Mechanism

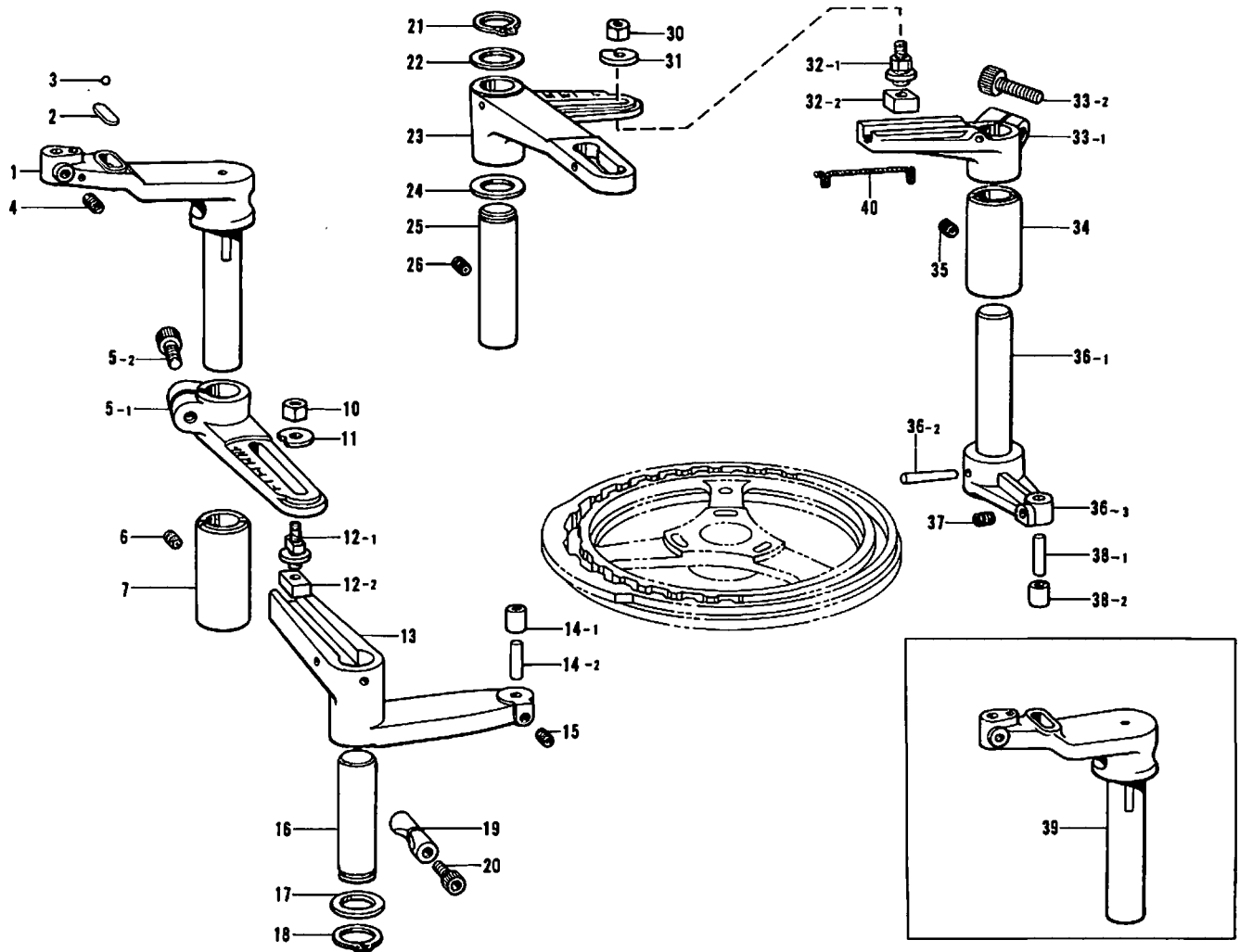

Ref. No.	Name of Parts	Q'ty	Parts No.	Assembly No.	Ref. No.	Name of Parts	Q'ty	Parts No.	Assembly No.
F- 1	Tack Length Lever 100	1			F-22	Washer 18	1	152756-0-01	
F- 2	Washer	1	153393-0-01		F-23	Tack Width Lever	1	156072-0-01	
F- 3	Steel Ball 3/16	1	071047-6-50		F-24	Washer 18	1	152756-0-01	
F- 4	Screw 5.95	1	152718-0-01		F-25	Tack Width Lever Shaft	1	152760-0-01	
F- 5-1	Tack Length Regulator Lever	1		F-5 Tack Length Regulator Lever Assembly	F-26	Screw 5.95 x 6	1	014760-6-22	
F- 5-2	Bolt 8 x 20	1	018082-0-22		F-30	Nut	1	152750-0-01	
F- 6	Screw 5.95 x 6	1	014760-6-22		F-31	Washer	1	152749-0-01	
F- 7	Bushing	1	152745-0-01		F-32-1	Tack Regulator Shaft	1		F-32 Tack Regulator Shaft Assembly 153042-0-01
F-10	Nut	1	152750-0-01		F-32-2	Slide Block	1		
F-11	Washer	1	152749-0-01		F-33-1	Tack Width Regulator Lever	1		F-33 Tack Width Regulator Lever Assembly 156321-0-01
F-12-1	Tack Regulator Shaft	1		F-12 Tack Regulator Shaft Assembly 153042-0-01	F-33-2	Bolt 8 x 20	1	018082-0-22	
F-12-2	Slide Block	1			F-34	Bushing	1	152745-0-01	
F-13	Tack Length Lever	1	153351-0-01		F-35	Screw 5.95 x 6	1	014760-6-22	
F-14-1	Roller	1		F-14 Cam Roller Assembly	F-36-1	Tack Width Feed Shaft	1		F-36 Tack Width Feed Shaft Assembly
F-14-2	Roller 5 x 19.8	1			F-36-2	Taper Pin 4 x 32	1	152738-0-01	
F-15	Screw 4.37 x 6	1	014680-6-22		F-36-3	Tack Width Lever	1		
F-16	Tack Length Lever Shaft	1			F-37	Screw 4.37 x 6	1	014680-6-22	
F-17	Washer 18	1	152756-0-01		F-38-1	Roller 5 x 19.8	1		F-38 Cam Roller Assembly
F-18	Stop Ring C18	1	048180-1-42		F-38-2	Roller	1		
F-19	Sleeve	1	152725-0-00		F-39	Tack Length Lever 140	1		
F-20	Bolt 6 x 30	1	018063-0-22		F-40	Wick 4 x 4	1	152968-0-01	
F-21	Stop Ring C18	1	048180-1-42						

G. Vertical Shaft Mechanism

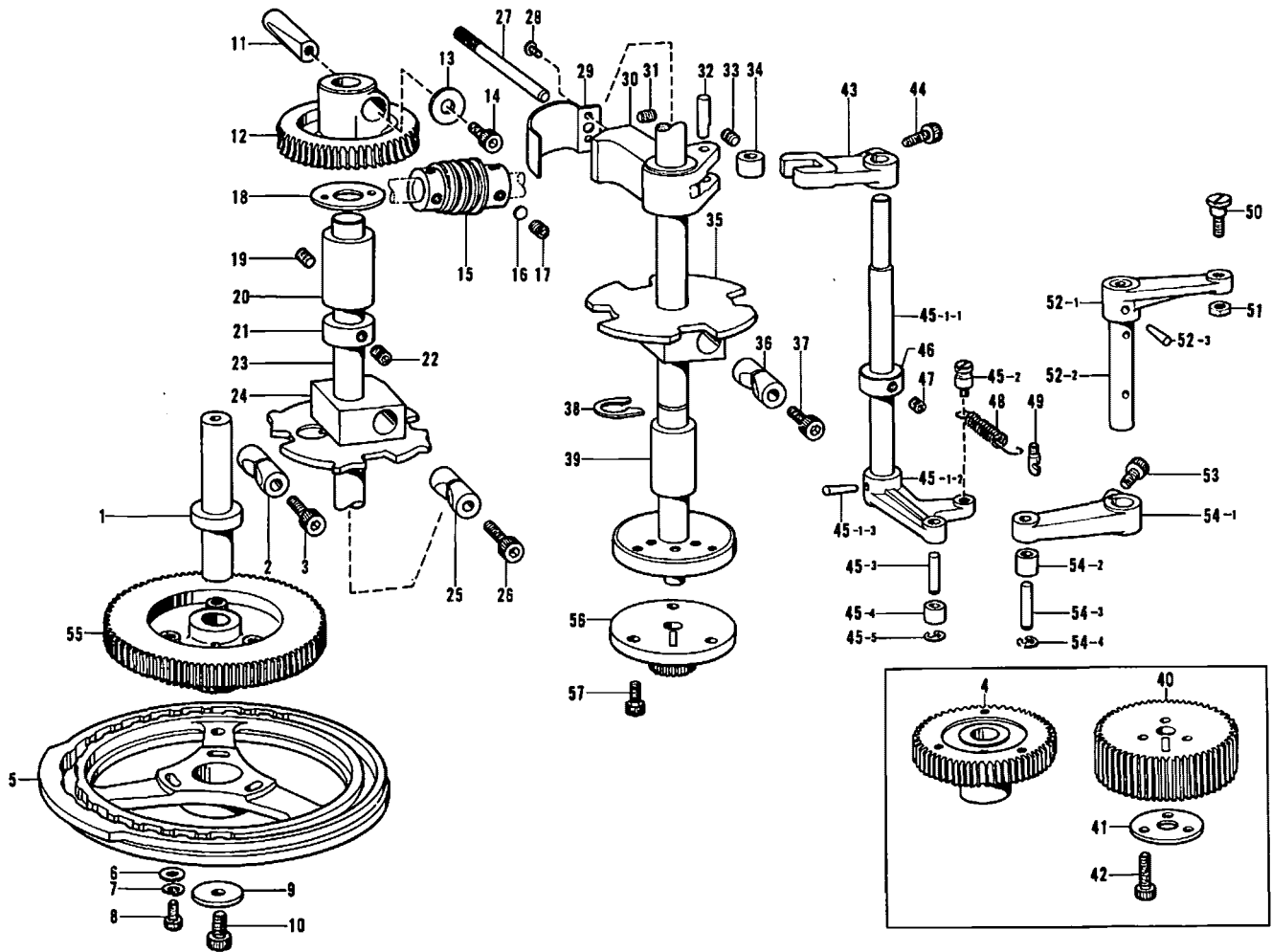

Ref. No.	Name of Parts	Q'ty	Parts No.	Assembly No.	Ref. No.	Name of Parts	Q'ty	Parts No.	Assembly No.
G-1	Tack Length Feed Cam Shaft	1	152724-0-01		G-35	Knife Cam	1	152730-0-01	
G-2	Sleeve	1	152725-0-00		G-36	Sleeve	1	152725-0-00	
G-3	Bolt 6 x 30	1	018063-0-22		G-37	Bolt 6 x 30	1	018063-0-22	
G-4	Change Gear (C)	1			G-38	Stop Ring	1	152723-0-01	
G-5	Feed Cam	1	*		G-39	Vertical Shaft Bushing (D)	1	152712-0-01	
G-6	Washer 8	3	109893-0-02		G-40	Change Gear (W)	1		
G-7	Washer 2-6	3	028060-2-42		G-41	Washer	1		
G-8	Bolt 6 x 20	3	018062-0-22		G-42	Bolt 6 x 22	3		
G-9	Washer 8	1	152728-0-01		G-43	Roller Holder Lever	1	152734-0-01	
G-10	Bolt 8 x 15	1	151163-0-01		G-44	Bolt 6 x 16	1	018061-6-22	
G-11	Sleeve	1	152709-0-00		G-45-1-1	Roller Holder Lever Shaft	1		G-45-1 Roller Holder Lever Shaft Assembly 153332-0-01
G-12	Worm Wheel	1	152708-0-00		G-45-1-2	Roller Holder Cam Lever	1		
G-13	Washer	1	152710-0-01		G-45-1-3	Taper Pin 3 x 20	1	046302-0-20	
G-14	Bolt 6 x 20	1	018062-0-22		G-45-2	Spring Hook	1	155337-0-01	G-45 Roller Holder Cam Lever Assembly 152735-1-01
G-15	Worm	1	152707-0-01		G-45-3	Pin	1	152739-0-01	
G-16	Washer	1	147151-0-00		G-45-4	Roller	1	153195-0-01	
G-17	Screw 5.95	6	152718-0-01		G-45-5	Stop Ring E4	1	048040-3-42	
G-18	Washer	1	152713-0-01		G-46	Collar	1	110027-0-01	
G-19	Screw 5.95 x 6	1	014760-6-22		G-47	Screw 5.95 x 6	2	014760-6-22	
G-20	Vertical Shaft Bushing (U)	1	152711-0-00		G-48	Spring	1	155336-0-01	
G-21	Coller	1	141816-0-01		G-49	Spring Hook	1	141334-0-01	
G-22	Screw 6.35 x 6	2	014770-6-22		G-50	Screw 5.95	1	151907-0-01	
G-23	Vertical Shaft Assembly	1	152715-0-01		G-51	Nut 5.95	1	150353-0-01	
G-24	Clutch Cam	1	152729-0-01		G-52-1	Clutch Actuating Lever	1		G-52 Clutch Actuating Lever Assembly 151939-0-01
G-25	Sleeve	1	152725-0-00		G-52-2	Clutch Actuating Lever Shaft	1		
G-26	Bolt 6 x 30	1	018063-0-22		G-52-3	Taper Pin	1	107030-0-01	
G-27	Emergency Stop Lever	1	152733-0-01		G-53	Bolt 6 x 20	1	018062-0-22	
G-28	Screw 3.57 x 4	2	009670-4-12		G-54-1	Clutch Cam Lever	1		G-54 Clutch Cam Lever Assembly 151939-0-01
G-29	Cover	1	153141-0-01		G-54-2	Roller	1	152914-0-01	
G-30	Roller Holder	1	152731-0-01		G-54-3	Roller Stud	1	152913-0-01	
G-31	Screw 4.76	1	013710-7-12		G-54-4	Stop Ring E4	1	048040-3-42	
G-32	Pin	1	152732-0-01		G-55	Change Gear (C)	1		
G-33	Screw 4.76	1	013710-7-12		G-56	Change Gear (W)	1		
G-34	Roller	1	152914-0-01		G-57	Bolt 6 x 14	3		

H. Work Clamp and Thread Wiper Mechanism

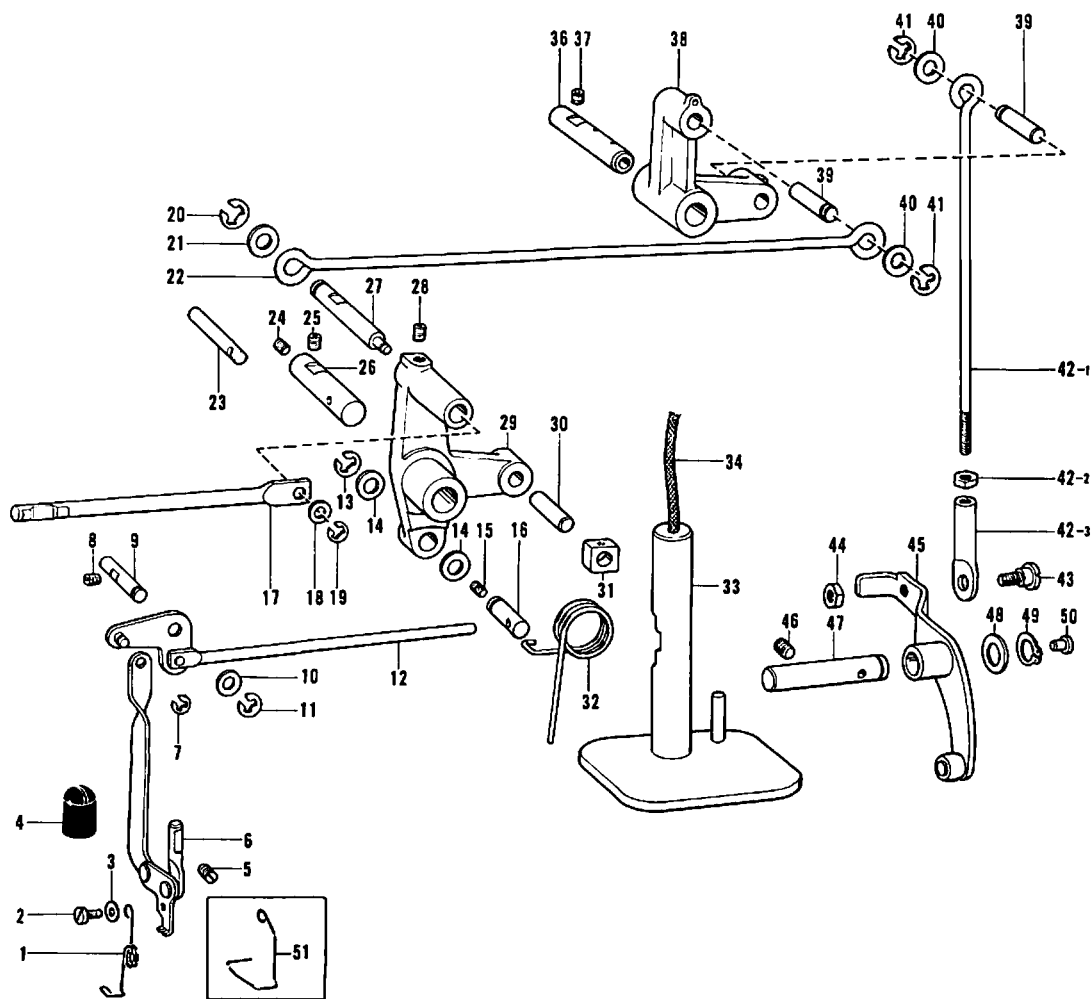

Ref. No.	Name of Parts	Q'ty	Parts No.	Assembly No.	Ref. No.	Name of Parts	Q'ty	Parts No.	Assembly No.
H- 1	Thread Wiper	1			H-27	Work Clamp Lifter Rod Shaft (A)	1	152802-0-01	
H- 2	Screw 3.57 x 5	1	009670-5-12		H-28	Screw 5.95 x 6	1	014760-6-22	
H- 3	Washer 3.5	1	025350-1-32		H-29	Work Clamp Lifter Lever	1	152798-0-01	
H- 4	Oil Cap	1	152827-0-01		H-30	Tack Length Slide Block Pin	1	152744-0-01	
H- 5	Screw 4.76	1	013710-7-12		H-31	Needle Bar Guide Slide Block	1	102630-0-01	
H- 6	Thread Wiper Link Assembly	1	152823-0-01		H-32	Spring	1	152800-2-01	
H- 7	Stop Ring E3	1	048030-3-42		H-33	Work Clamp Lifter Plate Assembly	1	152794-0-01	
H- 8	Screw 4.37 x 6	1	014680-6-22		H-34	Wick 4 x 4	1	152968-0-01	
H- 9	Thread Wiper Shaft	1	152822-0-01		H-36	Lifting Lever Shaft (T)	1	154183-0-01	
H-10	Washer 6.35	1	025770-2-32		H-37	Screw 5.95 x 6	1	014760-6-22	
H-11	Stop Ring E4	1	048040-3-42		H-38	Connecting Lever	1	152805-0-01	
H-12	Thread Wiper Rod Assembly	1	152816-0-01		H-39	Connecting Lever Shaft (B)	2	152806-0-01	
H-13	Stop Ring E6	1	048060-3-42		H-40	Washer	2	107153-0-02	
H-14	Washer	2	116629-0-01		H-41	Stop Ring E6	2	048060-3-42	
H-15	Screw 4.37 x 6	1	014680-6-22		H-42-1	Connecting Rod	1	154332-0-01	H-42 Connecting Rod Assembly 152808-1-01
H-16	Thread Wiper Rod Shaft	1	152815-0-01		H-42-2	Nut 6.35	1	150555-0-01	
H-17	Tension Release Bar	1	152874-0-01		H-42-3	Joint	1	154333-0-01	
H-18	Washer	1	140208-0-01		H-43	Screw 6.35	1	141583-0-01	
H-19	Stop Ring E4	1	048040-3-42		H-44	Nut 6.35	1	150555-0-01	
H-20	Stop Ring E6	1	048060-3-42		H-45	Connecting Lever	1	152811-0-01	
H-21	Washer	1	107153-0-02		H-46	Screw 5.95 x 6	1	014760-6-22	
H-22	Work Clamp Lifter Rod (A)	1	152803-0-01		H-47	Driving Shaft	1	152924-0-01	
H-23	Pin	1	152801-0-01		H-48	Horizontal Feed Crank Ring	1	142628-0-01	
H-24	Screw 5.95	1	013760-6-12		H-49	Stop Ring C11	1	048110-1-42	
H-25	Screw 5.95 x 6	1	014760-6-22		H-50	Cap for Oil Inlet	1	111865-0-01	
H-26	Work Clamp Lifter Lever Shaft	1	152799-0-01		H-51	Finger Guard	1		

J. Thread Trimming and Thread Nipper Mechanism

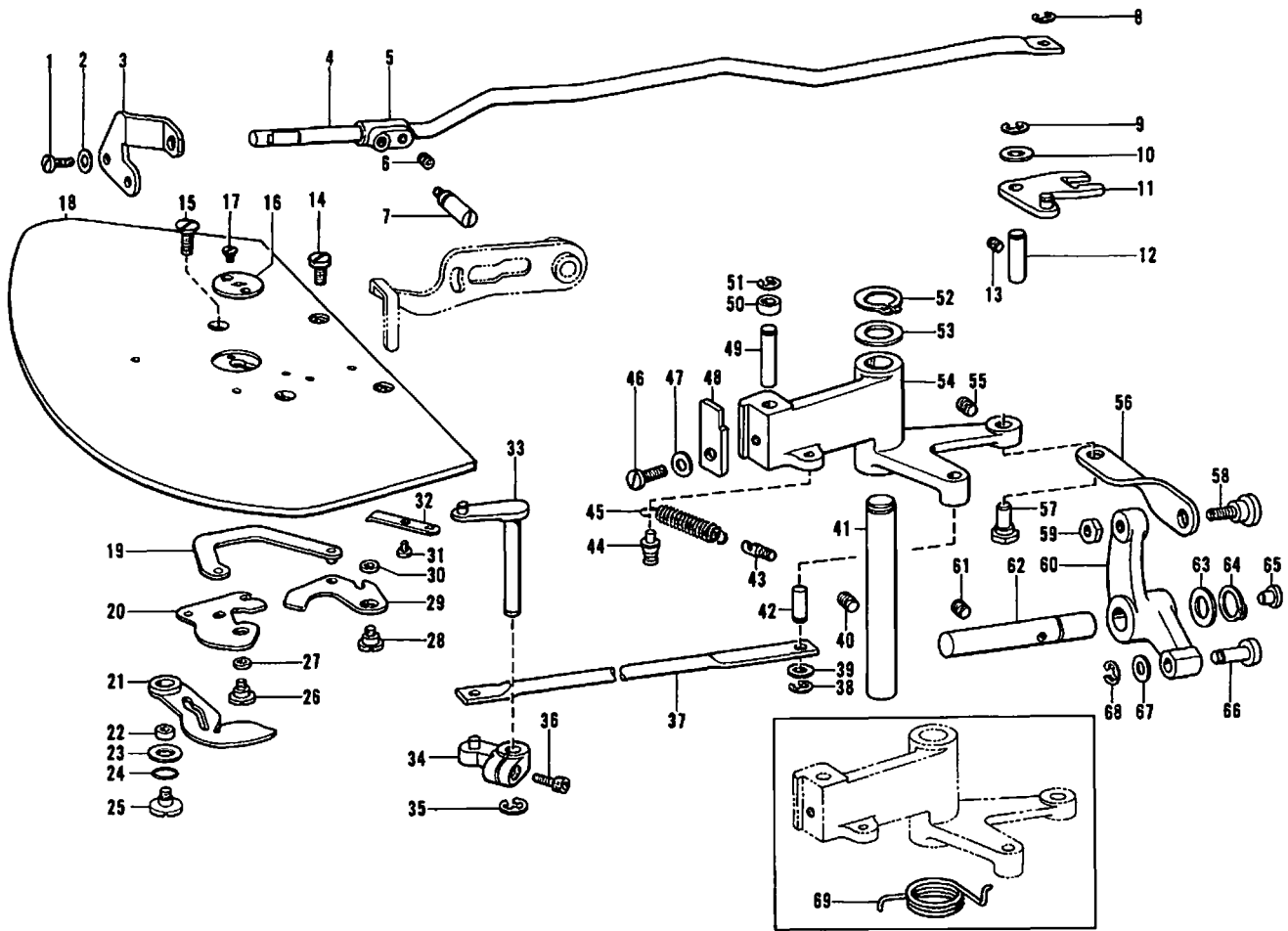

Ref. No.	Name of Parts	Q'ty	Parts No.	Assembly No.	Ref. No.	Name of Parts	Q'ty	Parts No.	Assembly No.
J-1	Screw 3.57 x 10	2	009671-0-12		J-36	Bolt 4.37 x 10	1	018681-0-22	
J-2	Washer 3.5	2	025350-3-32		J-37	Connecting Rod	1	152892-0-01	
J-3	Tension Release Bar Plate	1	152926-0-01		J-38	Stop Ring E4	1	048040-3-42	
J-4	Tension Release Bar	1	152925-1-01		J-39	Washer	1	140208-0-01	
J-5	Thread Take-up Guide	1	152886-0-01		J-40	Screw 5.95 x 6	1	014760-6-22	
J-6	Screw 4.37 x 4	1	014680-4-22		J-41	Shaft	1	152916-0-01	
J-7	Guide Stud	1	152887-0-01		J-42	Pin	1	152919-0-01	
J-8	Stop Ring E4	1	048040-3-42		J-43	Spring Hook	1	141334-0-01	
J-9	Stop Ring E5	1	048050-3-42		J-44	Spring Hook	1	154789-0-01	
J-10	Washer 6.35	1	025770-2-32		J-45	Spring	1	154788-0-01	
J-11	Tension Release Lever	1	152988-0-01		J-46	Screw 5.95 x 14	1	009761-4-12	
J-12	Tension Release Lever Shaft	1	152929-0-01		J-47	Washer 6	1	025060-1-32	
J-13	Screw 5.95 x 6	1	014760-6-22		J-48	Cam Lever Claw	1	152915-0-01	
J-14	Screw 4.37	2	153208-0-02		J-49	Roller Stud	1	152913-0-01	
J-15	Screw 4.37	2	100032-0-04		J-50	Roller	1	152914-0-01	
J-16	Needle Hole Plate	1			J-51	Stop Ring E4	1	048040-3-42	
J-17	Screw 2.38	2	100360-0-03		J-52	Stop Ring C12	1	048120-1-42	
J-18	Needle Plate	1			J-53	Washer	1	152917-0-01	
J-19	Knife Connecting Rod Assembly	1	152897-1-01		J-54	Cam Lever	1	152912-0-01	
J-20	Movable Knife Assembly	1			J-55	Screw 5.95 x 6	1	014760-6-22	
J-21	Thread Retainer	1			J-56	Thread Trimming Link	1	152921-0-01	
J-22	Collar	1	153597-0-01		J-57	Stud	1	152920-0-01	
J-23	Washer	1	153596-0-01		J-58	Screw 5.95	1	151907-0-01	
J-24	Packing P8	1	081008-0-70		J-59	Nut 5.95	1	150553-0-01	
J-25	Screw 4.37	1	153598-0-01		J-60	Thread Trimming Lever	1	152922-0-01	
J-26	Screw 4.37	1	152904-0-01		J-61	Screw 5.95 x 6	1	014760-6-22	
J-27	Collar	1	153219-0-01		J-62	Driving Shaft	1	153482-0-01	
J-28	Screw 4.37	1	153222-0-01		J-63	Horizontal Feed Crank Ring	1	142628-0-01	
J-29	Knife Arm (C)	1	152981-0-01		J-64	Stop Ring C11	1	048110-1-42	
J-30	Collar	1	153220-0-01		J-65	Cap for Oil Inlet	1	111865-0-01	
J-31	Screw 2.38	2	111140-0-02		J-66	Roller	1	152923-0-01	
J-32	Fixed Knife	1	152905-0-01		J-67	Washer	1	112468-0-01	
J-33	Thread Trimming Arm (B)	1	152893-1-01		J-68	Stop Ring E5	1	048050-3-42	
J-34	Thread Trimming Arm (A) Assembly	1	152896-0-01		J-69	Spring (B)	1		
J-35	Stop Ring E5	1	048050-3-42						

K. Bobbin Winder and Threading Mechanism

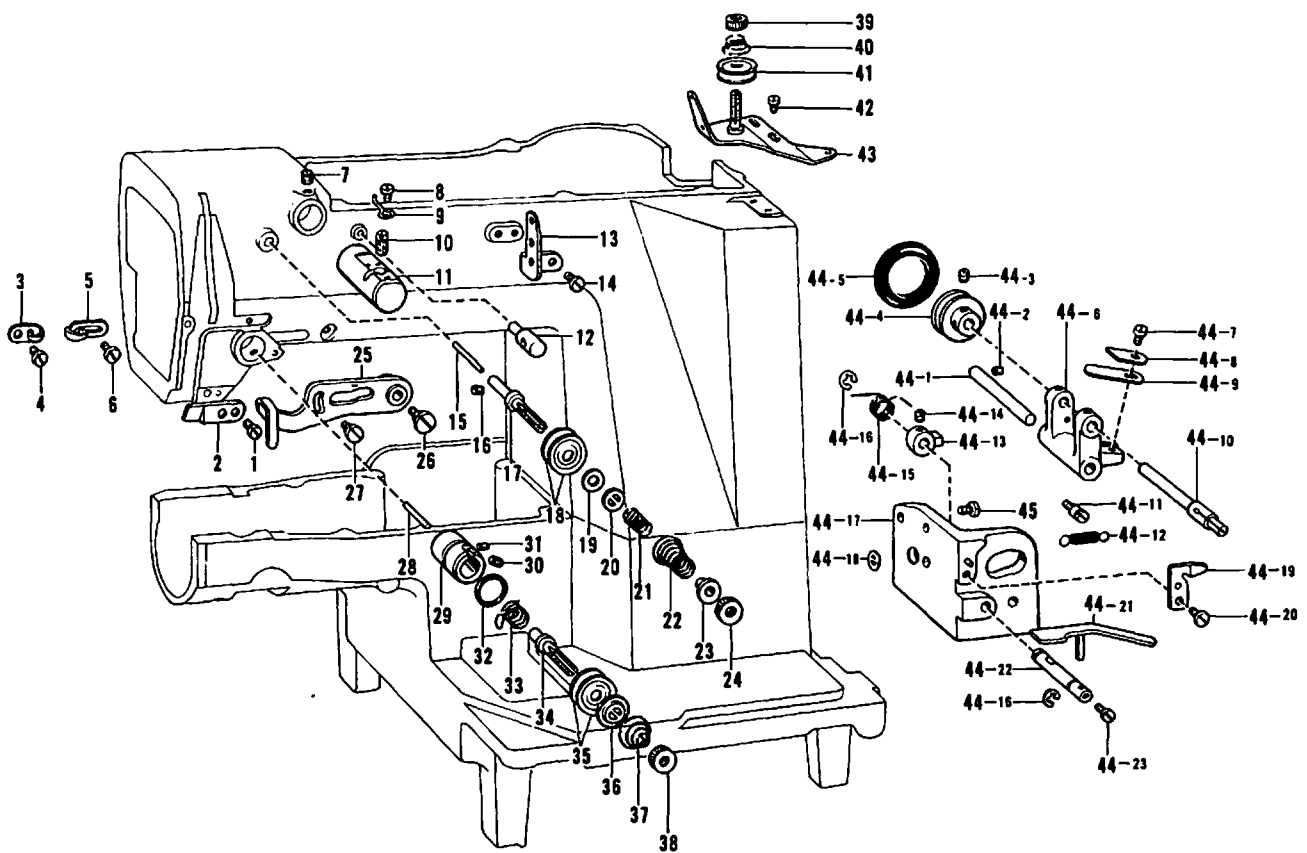

Ref. No.	Name of Parts	Q'ty	Parts No.	Assembly No.	Ref. No.	Name of Parts	Q'ty	Parts No.	Assembly No.
K-1	Screw 4.76 x 7	1	009710-7-12		K-35	Tension Disc	2	145446-0-01	
K-2	Arm Thread Guide	1	152869-0-01		K-36	Presser for Tension Disc	1	100134-0-01	
K-3	Arm Thread Guide	1	152870-0-01		K-37	Tension Spring	1		
K-4	Screw 3.57 x 6	1	009670-6-12		K-38	Tension Control Nut	1	100136-0-01	
K-5	Arm Thread Guide	1	113316-0-01		K-39	Tension Control Nut	1	100136-0-01	
K-6	Screw 3.57	1	112751-0-03		K-40	Tension Spring	1	104525-0-01	
K-7	Screw 5.95	1	013760-6-12		K-41	Tension Disc	2	145446-0-01	
K-8	Screw 3.57 x 4	1	009670-4-12		K-42	Screw 4.37 x 10	2	009681-0-12	
K-9	Needle Cooler Thread Guide	1	152884-0-01		K-43	Lower Thread Tension Bracket Assembly	1	152945-0-01	
K-10	Felt 7 x 15.5	1	152883-0-00		K-44-1	Bobbin Winder Lever Shaft	1	152934-0-01	K-44 Bobbin Winder Assembly 152982-1-01
K-11	Needle Cooler Assembly	1	152881-0-01		K-44-2	Screw 4.37	1	102716-0-04	
K-12	Upper Thread Guide Bar	1	153049-0-01		K-44-3	Screw 4.37	2	102716-0-04	
K-13	Thread Retainer	1	152889-0-01		K-44-4	Bobbin Winder Wheel	1	154528-0-01	
K-14	Screw 3.57 x 6	2	009670-6-12		K-44-5	Rubber Ring	1	120448-0-01	
K-15	Tension Release Pin	1	152876-0-01		K-44-6	Bobbin Winder Lever	1	152984-0-01	
K-16	Screw 4.37	1	151601-0-02		K-44-7	Screw 3.57 x 7	1	009670-7-12	
K-17	Tension Stud	1	152875-0-01		K-44-8	Washer	1	152937-0-01	
K-18	Tension Disc	2	145446-0-01		K-44-9	Plate Spring	1	152936-0-01	
K-19	Washer	1	153138-0-01		K-44-10	Bobbin Winder Shaft	1	152933-0-01	
K-20	Tension Disc Washer	1	152877-0-01		K-44-11	Sustainer	1	141550-0-01	
K-21	Tension Spring	1	152878-0-01		K-44-12	Spring	1	152939-0-01	
K-22	Tension Spring	1	152879-1-01		K-44-13	Claw for Bobbin Winder	1	142566-0-01	
K-23	Washer	1	152880-0-01		K-44-14	Screw 4.37	2	151601-0-01	
K-24	Tension Control Nut	1	100136-0-01		K-44-15	Spring	1	152941-0-01	
K-25	Thread Take-up Lever	1	152888-0-01		K-44-16	Stop Ring E5	2	048050-3-42	
K-26	Screw 6.35	1	141528-0-01		K-44-17	Bobbin Winder Bracket	1	152983-0-01	
K-27	Screw 4.76	1	115077-0-03		K-44-18	Spring Hook	1	115138-0-01	
K-28	Tension Release Pin	1	152873-0-01		K-44-19	Knife	1	152938-0-01	
K-29	Tension Bracket	1	152872-0-01		K-44-20	Screw 4.37 x 7	1	009680-7-12	
K-30	Screw 5.95	1	103950-0-02		K-44-21	Bobbin Presser	1	152935-0-01	
K-31	Screw 3.57	1	100402-0-04		K-44-22	Claw Stud for Bobbin Winder	1	152940-0-01	
K-32	Packing	1	114294-0-01		K-44-23	Screw 3.57 x 7	1	009670-7-12	
K-33	Thread Take-up Spring	1			K-45	Screw 5.95 x 14	2	009761-4-12	
K-34	Tension Stud	1	100398-0-01						

L. Oil Pan

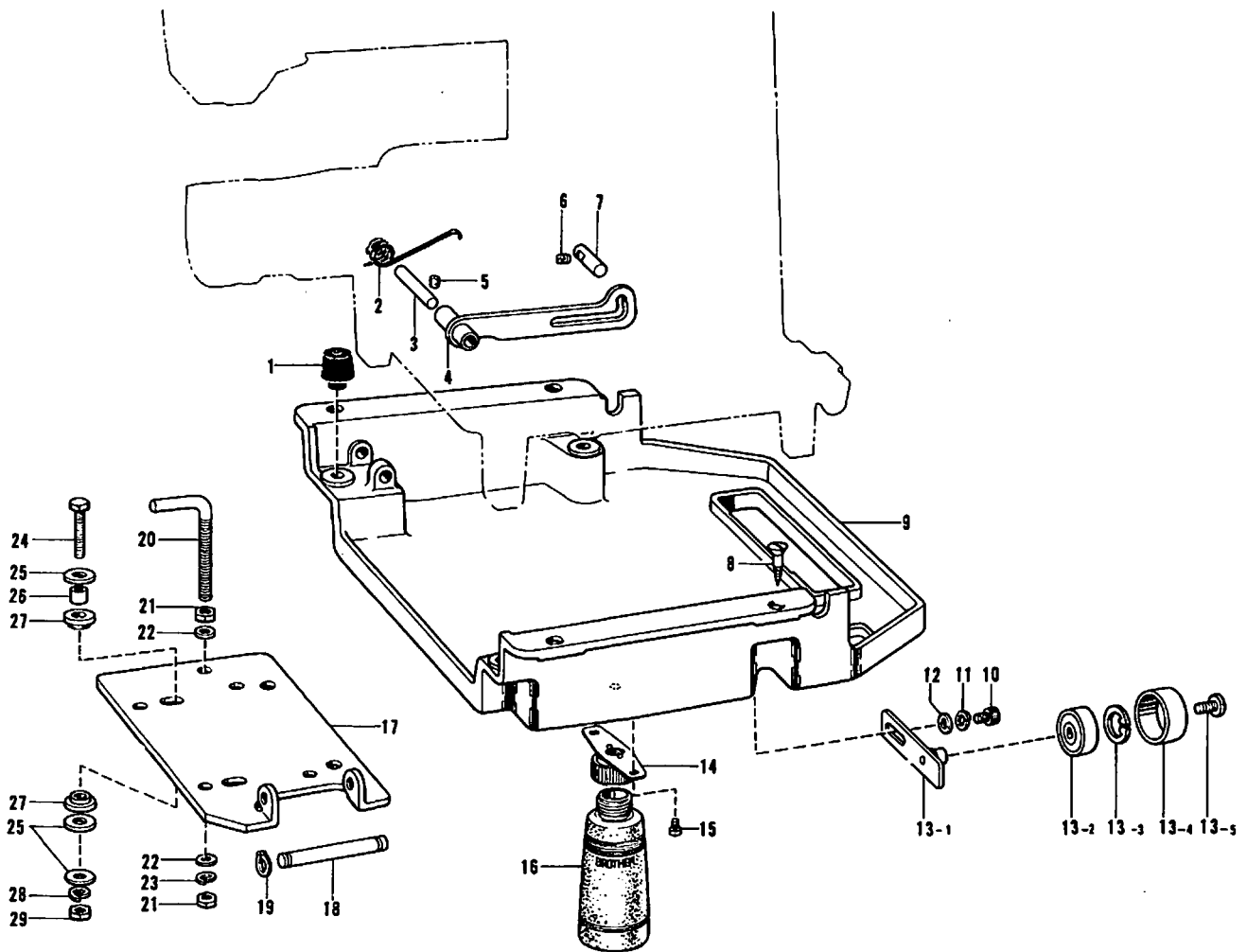

Ref. No.	Name of Parts	Q'ty	Parts No.	Assembly No.	Ref. No.	Name of Parts	Q'ty	Parts No.	Assembly No.
L- 1	Bed Cushion	4	152860-0-01		L-14	Dust Oiler Supporter	1	154465-0-01	
L- 2	Head Supporter Lever Spring	1	152859-0-01		L-15	Screw 4.76 x 6	2	009710-6-12	
L- 3	Head Supporter Lever Shaft	1	152858-0-01		L-16	Oiler	1	114486-0-01	
L- 4	Head Supporter Lever	1	152857-0-01		L-17	Motor Base Plate	1	152861-1-01	
L- 5	Screw 4.76	1	013719-4-12		L-18	Motor Base Plate Shaft	1	152862-0-01	
L- 6	Screw 5.95	1	013760-6-12		L-19	Stop Ring C10	2	048100-1-42	
L- 7	Pin	1	152866-0-01		L-20	Bolt M10	1	152865-0-01	
L- 8	Screw 6.2 x 32	4	106030-0-01		L-21	Nut 10	2	021100-2-02	
L- 9	Oil Pan	1	154738-0-01		L-22	Washer 10	2	025100-1-32	
L-10	Bolt 8 x 12	1	018081-2-22		L-23	Washer 2-10	1	028100-2-42	
L-11	Washer 2-8	1	028080-2-42		L-24	Bolt 6 x 25	4	017062-5-03	
L-12	Washer 8	1	025080-2-32		L-25	Washer 7 14	12	025800-3-33	
L-13-1	Tension Pulley Plate	1		L-13 Tension Pulley Assembly 152852.1-01	L-26	Cushion Collar	4	152863-0-01	
L-13-2	Ball Bearing 6201VV	1			L-27	Cushion	8	152864-0-00	
L-13-3	Stop Ring C32	1	048320-2-42		L-28	Washer 2-6	4	028060-2-42	
L-13-4	Tension Pulley	1			L-29	Nut 6	4	021060-1-02	
L-13-5	Screw 6.35	1	141860-0-01						

M. Lubrication

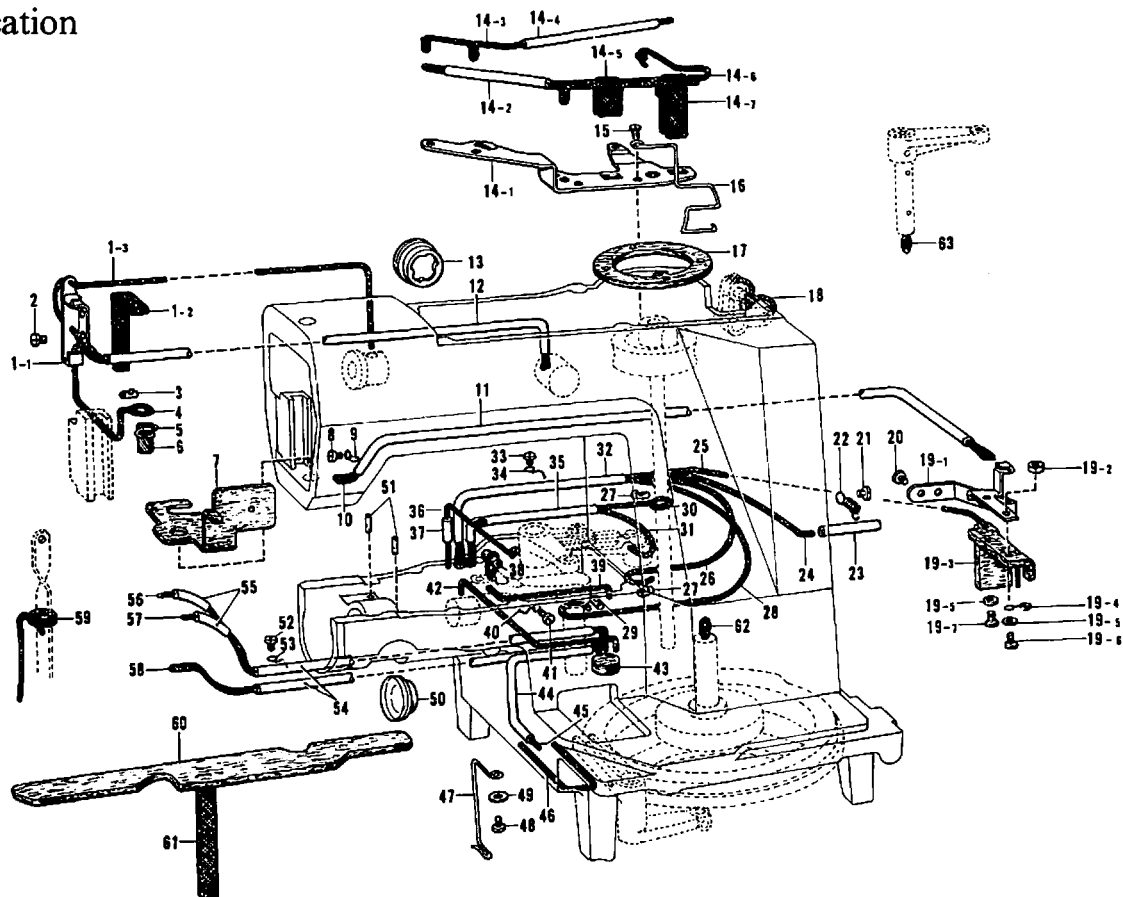

Ref. No.	Name of Parts	Q'ty	Parts No.	Assembly No.	Ref. No.	Name of Parts	Q ty	Parts No.	Assembly No.
M-1-1	Wick Supporter	1	152959-0-01	M-1	M-26	Wick 4 x 4	1	152965-0-01	
M-1-2	Wick	1	152955-0-01	M-1	M-27	Wick Supporter	2	104567-0-01	
M-1-3	Wick 4 x 4	1	152956-0-01	M-1	M-28	Wick 4 x 4	1	153922-0-01	
M-2	Screw 4.37 x 6	1	009680-6-12	M-1	M-29	Wick Supporter	1	104567-0-01	
M-3	Wick Supporter	1	104567-0-01	M-1	M-30	Wick 6 x 6	1	152964-0-01	
M-4	Wick 4 x 4	1	152956-0-01	M-1	M-31	Wick 6 x 6	1	152964-0-01	
M-5	Wick Supporter	1	152962-0-01	M-1	M-32	Oil Tube	1	148921-0-00	
M-6	Wick	1	152960-0-01	M-1	M-33	Screw 3.57 x 5	1	009670-5-12	
M-7	Felt	1	153530-0-01	M-1	M-34	Cord Supporter	1	152969-0-01	
M-8	Screw 3.57 x 5	1	009670-5-12	M-1	M-35	Oil Tube	1	147745-0-00	
M-9	Cord Supporter	1	117150-0-01	M-1	M-36	Wick 4 x 4	1	152974-0-01	
M-10	Wick	1	152992-0-01	M-1	M-37	Oil Tube	1	148735-0-01	
M-11	Oil Tube	1	146375-0-00	M-1	M-38	Felt	1	153924-0-01	
M-12	Oil Tube	1	144694-0-01	M-1	M-39	Wick 4 x 4	1	153921-0-01	
M-13	Oil Gauge Window	1	152948-0-01	M-1	M-40	Cord Supporter	1	117150-0-01	
M-14-1	Wick Supporter	1	152950-0-01	M-1	M-41	Screw 3.57 x 5	1	009670-5-12	
M-14-2	Oil Tube	1	140423-0-00	M-1	M-42	Wick 4 x 4	1	152973-0-01	
M-14-3	Wick 6 x 6	1	153919-0-01	M-1	M-43	Felt	1	113006-0-01	
M-14-4	Oil Tube	1	147745-0-00	M-1	M-44	Oil Tube	1	147745-0-00	
M-14-5	Felt	1	152952-0-01	M-1	M-45	Wick 6 x 6	1	152953-0-01	
M-14-6	Wick 6 x 6	1	153918-0-01	M-1	M-46	Wick 4 x 4	1	153920-0-01	
M-14-7	Felt	1	152951-0-01	M-1	M-47	Wick Supporter	1	153763-0-01	
M-15	Screw 4.37 x 10	2	009681-0-2	M-1	M-48	Screw 3.57 x 5	1	009670-5-12	
M-16	Felt Supporter	1	153528-0-01	M-1	M-49	Washer	1	105248-0-01	
M-17	Felt	1	153529-0-01	M-1	M-50	Oil Gauge Window	1	152948-0-01	
M-18	Wick 6 x 6	1	153927-0-01	M-1	M-51	Pin	2	047251-6-40	
M-19-1	Felt Supporter	1	152966-0-01	M-1	M-52	Screw 3 57 x 5	1	009670-5-12	
M-19-2	Nut 3.57	1	021670-2-02	M-1	M-53	Cord Supporter	1	152969-0-01	
M-19-3	Felt	1	15296 -0-01	M-1	M-54	Oil Tube	2	140423-0-00	
M-19-4	Tube Stopper	1	141692-0-01	M-1	M-55	Oil Tube	2	148735-0-01	
M-19-5	Washer 3.5	3	025350-3-32	M-1	M-56	Wick 4 x 4	1	152972-0-01	
M-19-6	Screw 3.57 x 14	1	009671-4 12	M-1	M-57	Wick 4 x 4	1	153920-0-01	
M-19-7	Screw 3.57 x 8	2	009670-8-12	M-1	M-58	Wick 4 x 4	1	152971-0-01	
M-20	Screw 3.57 x 6	2	009670-6-12	M-1	M-59	Wick 4 x 4	1	152973-0-01	
M-21	Screw 4.37 x 8	1	009680-8-12	M-1	M-60	Felt	1	153531-0-01	
M-22	Tube Supporter	1	152978-0-01	M-1	M-61	Wick	1	53562-0-01	
M-23	Oil Tube	1	148735-0-01	M-1	M-62	Wick 6 x 6	1	152980 0-01	
M-24	Wick 4 x 4	1	153922-0-01	M-1	M-63	Wick 6 x 6	1	152980-0-01	
M-25	Wick 4 x 4	1	152963-0-01						

N. Two-Step Presser Mechanism

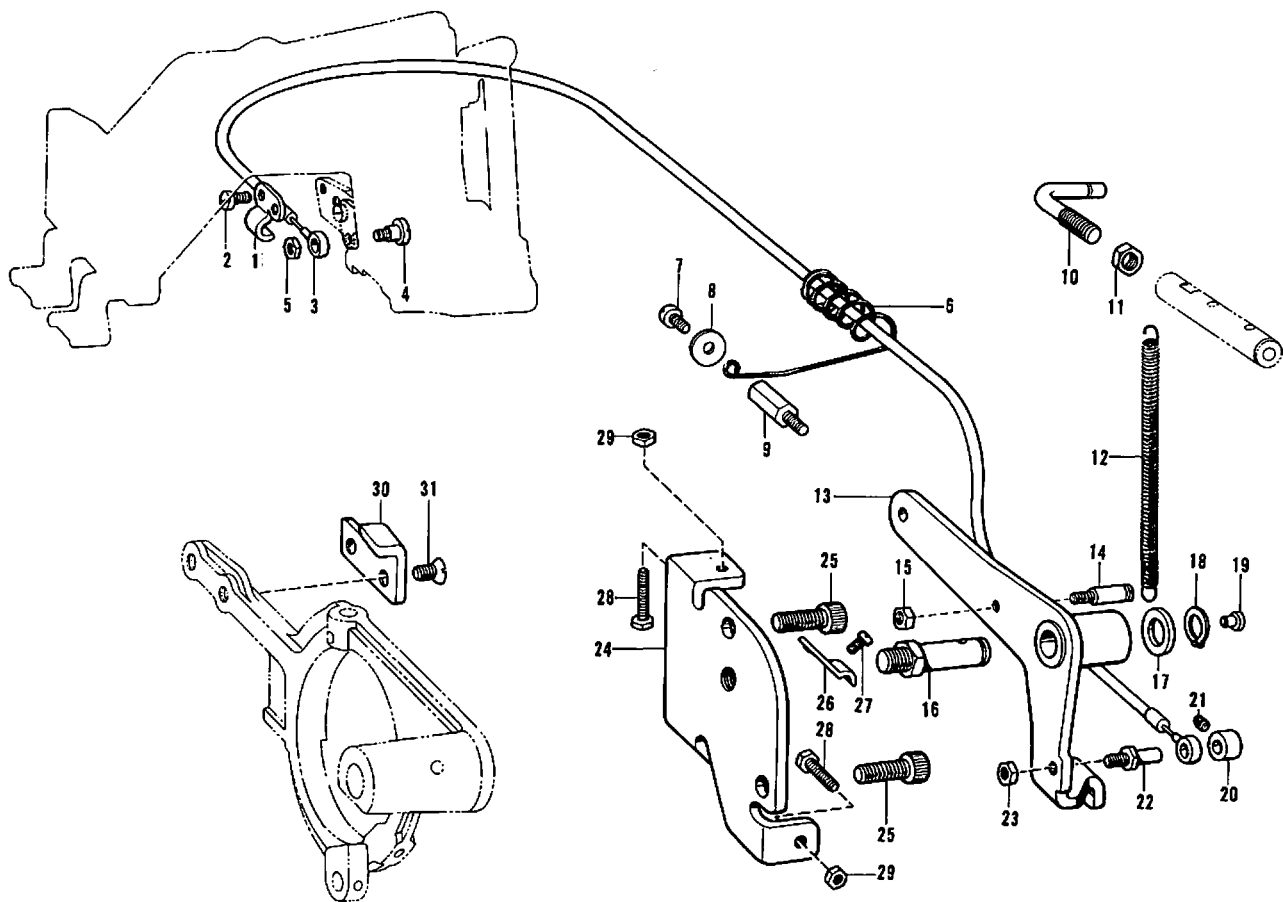

Ref. No.	Name of Parts	Q'ty	Parts No.	Assembly No.	Ref. No.	Name of Parts	Q'ty	Parts No.	Assembly No.
N- 1	Wire Holder	1	153941-0-01		N-17	Horizontal Feed Crank Ring	1	142628-0-01	
N- 2	Screw 4.76 x 6	1	009710-6-12		N-18	Stop Ring C11	1	048110-1-42	
N- 3	Flexible Wire Assembly	1	153938-0-01		N-19	Cap for Oil Inlet	1	111865-0-01	
N- 4	Screw 4.37	1	147476-0-01		N-20	Collar	1	120068-0-01	
N- 5	Nut 4.37	1	021680-2-02		N-21	Screw 4.37	1	151601-0-02	
N- 6	Wire Holder (L)	1	153958-0-01		N-22	Wire Pin	1	153934-0-01	
N- 7	Screw 4.76 x 7	1	009710-7-12		N-23	Nut 4.76	1	110161-0-04	
N- 8	Washer 5	1	025050-2-32		N-24	Starting Lever Bracket	1	153931-0-01	
N- 9	Bolt 4.76	1	153959-0-01		N-25	Bolt 8 x 15	2	151163-0-01	
N-10	Spring Hook (L)	1	153936-0-01		N-26	Wire Holder	1	153941-0-01	
N-11	Nut 7.14	1	100090-0-04		N-27	Screw 4.76 x 6	1	009710-6-12	
N-12	Spring	1	153937-0-01		N-28	Bolt 5.95 x 20	2	017762-0-12	
N-13	Starting Lever F	1	153932-0-01		N-29	Nut 5.95	2	150553-0-01	
N-14	Spring Hook	1	153935-0-01		N-30	Safety Lever F	1	153942-0-01	
N-15	Nut 4.76	1	110161-0-04		N-31	Screw 5.95 x 8	2	003760-8-12	
N-16	Starting Lever Shaft	1	153933-0-01						

Z. Accessories

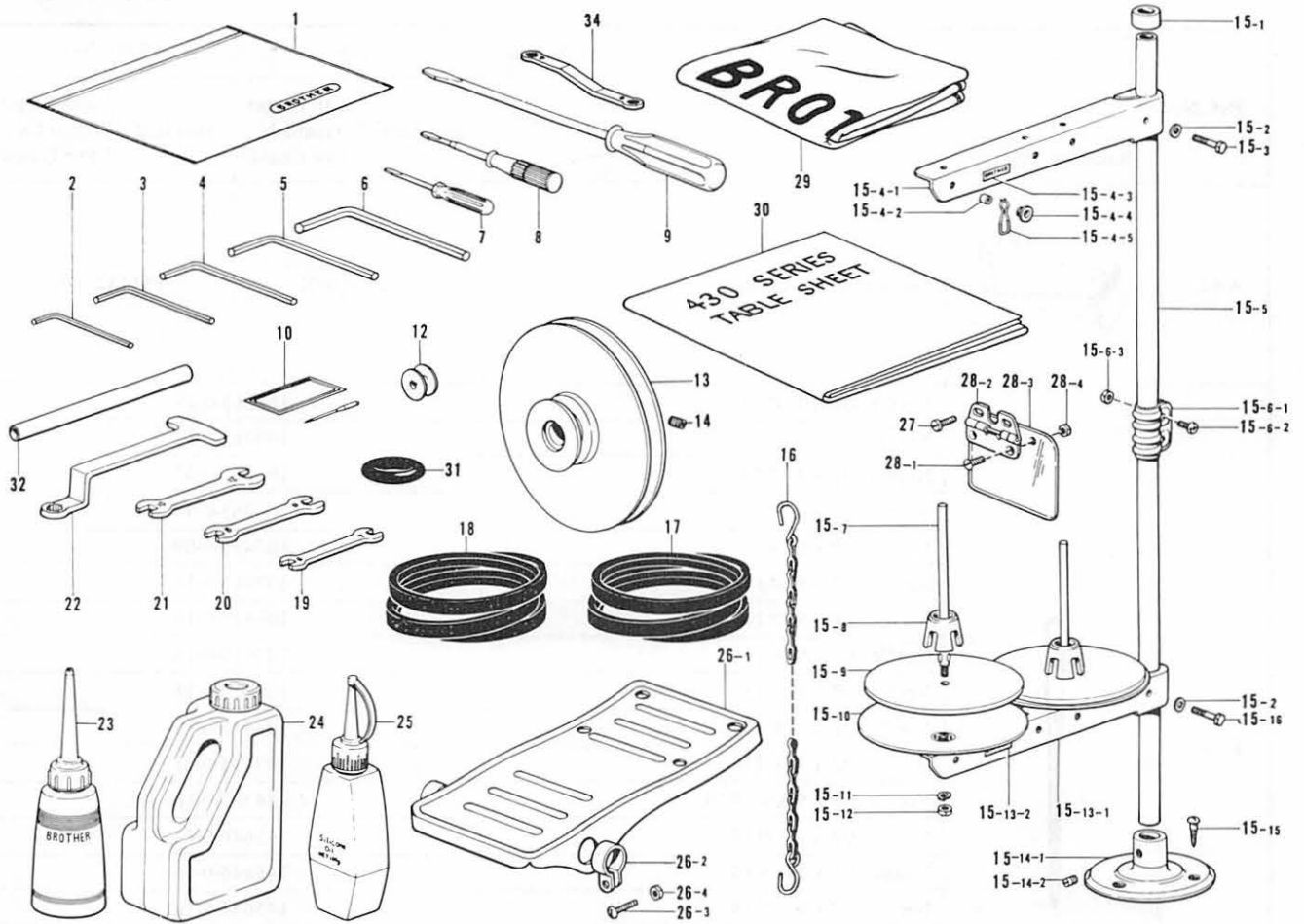

Ref. No.	Name of Parts	Q'ty	Parts No.	Assembly No.	Ref. No.	Name of Parts	Q'ty	Parts No.	Assembly No.
Z- 1	Vinyl Bag		122991-0-01		Z-15-14-1	Cotton Stand Base		150189-0-01	Z-15-14 Cotton Stand Base Assembly 150139-0-01
Z- 2	Spanner 2		142002-0-01		Z-15-14-2	Screw 6 x 7		150181-1-01	
Z- 3	Spanner 3		142721-0-01		Z-15-15	Screw 4.5 x 22		031452-2-03	Z-15 Cotton Stand Assembly 150150-0-01
Z- 4	Spanner 4		118064-0-01		Z-15-16	Bolt 5 x 28		017502-8-03	
Z- 5	Spanner 5		147487-0-01		Z-16	Chain		149247-0-01	
Z- 6	Spanner 6		115157-0-01		Z-17	V Belt (for Low Speed)		082104-8-90	
Z- 7	Screw Driver 1.9 x 52		142443-0-01		Z-18	V Belt (for High Speed)			
Z- 8	Screw Driver 3.4 x 70		118837-0-01		Z-19	Spanner 6 x 7		107779-0-01	
Z- 9	Screw Driver 5.5 x 190		101572-1-01		Z-20	Spanner 8 x 9		100887-0-01	
Z-10	Needle Assembly				Z-21	Spanner 10 x 12		107780-0-01	
Z-12	Bobbin				Z-22	Wrench 10		152765-0-01	
Z-13	Motor Pulley				Z-23	Oiler		114483-0-01	
Z-14	Screw 5.95 x 6		014760-6-22		Z-24	Oil Tank		154702-0-01	
Z-15- 1	Cap			Z-15 Cotton Stand Assembly 150150-0-01	Z-25	Silicon Oil		156334-0-02	
Z-15- 2	Washer 5		025050-2-33		Z-26- 1	Pedal		117437-1-01	Z-26 Pedal Assembly 116185-2-01
Z-15- 3	Bolt 5 x 28		017502-8-03		Z-26- 2	Pedal Stopper		116016-0-01	
Z-15- 4-1	Spool Holder 2			Z-15-4 Thread Hanger Assembly 150192-0-01	Z-26- 3	Screw 4 x 14		001401-4-16	
Z-15- 4-2	Thread Bushing		142990-0-01		Z-26- 4	Nut 4		021400-1-06	
Z-15- 4-3	Name Plate				Z-27	Screw 3.57 x 5			
Z-15- 4-4	Thread Hanger				Z-28- 1	Screw 3.57		102538-0-07	
Z-15- 4-5	Thread Guide Spring		150184-0-01		Z-28- 2	Eye Guard Hinge Assembly		153102-0-01	Z-28 Eye Guard Assembly
Z-15- 5	Pipe		150172-0-01		Z-28- 3	Eye Guard		153098-0-00	
Z-15- 6-1	Joint		150173-0-01	Z-15-6 Joint for Cotton Stand 150106-0-01	Z-28- 4	Nut 3.57		106129-0-01	
Z-15- 6-2	Screw 5 x 14		150202-0-01		Z-29	Head Cover		144226-0-01	
Z-15- 6-3	Nut 5		021500-1-03		Z-30	Table Sheet		153574-2-01	
Z-15- 7	Spool Shaft (B)		150179-0-01		Z-31	Rubber Ring		120448-0-01	
Z-15- 8	Spool Cushion		126863-0-00	Z-15 Cotton Stand Assembly 150150-0-01	Z-32	Pipe		154760-0-01	
Z-15- 9	Spool Mat		150182-0-00		Z-34	Wrench 8 x 9		105343-0-01	
Z-15-10	Spool Stand Base		150180-0-00						
Z-15-11	Washer 2-5		028050-2-43						
Z-15-12	Nut 5		021500-1-03						
Z-15-13-1	Spool Holder 2			Z-15-13 Spool Holder Assembly 150177-0-01					
Z-15-13-2	Name Plate								







*The details of included accessories are subject to change.



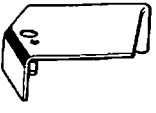









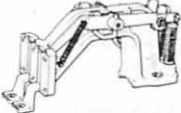

*Änderungen in der Aufstellung der mitgelieferten Zubehöre sind vorbehalten.





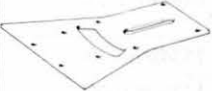

*Les détails des accessoires inclus sont sujets à des changements.



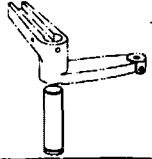

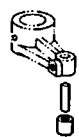
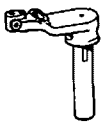
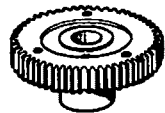

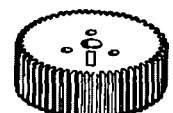
*Los detalles de los accesorios incluidos pueden variar.

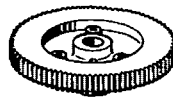



DIFFERENT PARTS LIST

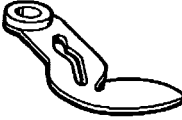

Ref. No.	Name of Parts	Sub-class	435		435-700	
			Standard	with Finger Guard & Eye Guard	Standard	with Finger Guard & Eye Guard
A-42		Bed Cover L Assembly	152836-0-02		154432-0-02	
B- 1		Needle DB x 1 # 9	100265-0-29			
		Needle DB x 1 #11	100265-0-31			
		Needle DB x 1 #23	100265-0-43			
		Needle DB x 1 #25	100265-0-45			
		Needle DP x 5 # 9	107415-0-09			
		Needle DP x 5 #11	107415-0-11			
		Needle DP x 5 #14	107415-0-14			
		Needle DP x 5 #16	107415-0-16			
		Needle DP x 5 #18	107415-0-18			
		Needle DP x 5 #19	107415-0-19			
		Needle DP x 5 #21	107415-0-21			
		Needle DP x 5 KN #10	154763-0-10			
		Needle DP x 17 #14	145646-0-14			
		Needle DP x 17 #16	145646-0-16			
		Needle DP x 17 #18	145646-0-18			
		Needle DP x 17 #19	145646-0-19			
		Needle DP x 17 #21	145646-0-21			
		Needle DP x 17 #24	145646-0-24			
Needle DP x 17 #25	145646-0-25					
Needle PF x 34 R # 8	148436-0-08					
B- 2		Needle Bar Thread Guide A	152890-0-01			
		Needle Bar Thread Guide B	154664-0-01			
B- 6		Needle Bar A (φ2.0)	152240-0-01			
		Needle Bar B (φ1.62)	152241-0-01			
		Needle Bar C (φ2.02)	153346-0-01			
B-64		Shuttle Hook A (for standard)	152685-0-01			
		Shuttle Hook B (for thick materials)	152687-0-01			
B-65		Shuttle Rece Ring A (for standard)	152682-0-01			
		Shuttle Rece Ring B (for thick materials)	152686-0-01			

Ref. No.	Name of Parts	Sub-class	435		435-700	
			Standard	with Finger Guard & Eye Guard	Standard	with Finger Guard & Eye Guard
B-66		Bobbin (for standard)	145265-0-01			
		Bobbin B (for thick materials)	154663-0-01			
B-67		Bobbin Case Assembly A (for standard)	152688-1-01			
		Bobbin Case Assembly B (for thick materials)	152690-1-01			
E- 1		Presser Arm Assembly SA5	153943-0-01			
		Presser Arm Assembly SB5	153973-0-01			
		Presser Arm Assembly LA5	153972-0-01			
		Presser Arm Assembly LB5	153974-0-01			
E- 1- 1		Work Clamp S	153368-0-01			
		Work Clamp L	153372-0-01			
E- 1-34		Presser Spring A (for standard)	153568-0-01			
		Presser Spring B (for thick materials)	153569-0-01			
E- 4		Feed Guide Cover S	153392-0-01			
		Feed Guide Cover L	153391-0-01			
E- 9		Bolt 4.37 x 5	017680-5-12			
		Bolt 4.37 x 7	153403-0-02			
E-10		Work Clamp Presser L	*			
E-11		Work Clamp Presser R	*			
E-14		Feed Plate	*			
E-16		Feed Guide Plate 100	156073-0-01	/		
E-18		Feed Guide Plate 140				
F- 1		Tack Length Lever 100	153347-1-01	/		
F- 5		Tack Length Regulator Lever Assembly	153762-1-01			
F-14		Cam Roller Assembly A (φ7.94)	153352-0-01			
		Cam Roller Assembly B (φ7)	153357-0-01			

Ref. No.	Sub-class	435		435-700		
		Standard	with Finger Guard & Eye Guard	Standard	with Finger Guard & Eye Guard	
Name of Parts						
F-16		Tack Length Lever Shaft A	152755-0-01			
		Tack Length Lever Shaft B	152755-0-02			
		Tack Length Lever Shaft C	152755-0-03			
F-36		Tack Width Feed Shaft Assembly A	154299-0-01			
		Tack Width Feed Shaft Assembly B	154320-0-01			
		Tack Width Feed Shaft Assembly C	154321-0-01			
F-38		Cam Roller Assembly ($\phi 7.94$)	153352-0-01			
		Cam Roller Assembly ($\phi 7$)	153357-0-01			
F-39		Tack Length Lever 140	/		153348-0-01	
G-4		Change Gear C (28 stitches)	152720-0-00			
		Change Gear C (35 stitches)	153313-0-00			
		Change Gear C (42 stitches)	152722-0-00			
G-5		Feed Cam	*			
G-40		Change Gear W (28 stitches)	152719-0-00			
		Change Gear W (35 stitches)	153312-0-00			
		Change Gear W (42 stitches)	152721-0-00			
G-41		Washer (for 28 ~ 42 stitches)	153104-0-01			
G-42		Bolt 6 x 22 (for 28 ~ 42 stitches)	018062-2-22			
G-55		Change Gear C (49 stitches)	153407-0-00			
		Change Gear C (56 stitches)	153408-0-00			
		Change Gear C (63 stitches)	153409-0-00			
		Change Gear C (70 stitches)	153410-0-00			
		Change Gear C (77 stitches)	153411-0-00			
		Change Gear C (84 stitches)	153412-0-00			
		Change Gear C (98 stitches)	153413-0-00			
		Change Gear C (112 stitches)	153414-0-00			
		Change Gear C (126 stitches)	153415-0-00			
		Change Gear C (140 stitches)	153417-0-00			
		Change Gear C (154 stitches)	153418-0-00			
Change Gear C (168 stitches)	153419-0-00					

Ref. No.	Name of Parts	Sub-class	435		435-700	
			Standard	with Finger Guard & Eye Guard	Standard	with Finger Guard & Eye Guard
G-56		Change Gear W (49 stitches)	153394-0-00			
		Change Gear W (56 stitches)	153395-0-00			
		Change Gear W (63 stitches)	153396-0-00			
		Change Gear W (70 stitches)	153397-0-00			
		Change Gear W (77 stitches)	153398-0-00			
		Change Gear W (84 stitches)	153399-0-00			
		Change Gear W (98 stitches)	153400-0-00			
		Change Gear W (112 stitches)	153401-0-00			
		Change Gear W (126 stitches)	153402-0-00			
		Change Gear W (140 stitches)	153404-0-00			
		Change Gear W (154 stitches)	153405-0-00			
		Change Gear W (168 stitches)	153406-0-00			
G-57		Bolt 6 x 14 (for 49 ~ 168 stitches)	018061-4-22			
H- 1		Thread Wiper	152828-0-01		152828-0-01	
H-51		Finger Guard		153046-0-01		153046-0-01
J-16		Needle Hole Plate A (φ1.6)	156149-0-01			
		Needle Hole Plate B (φ2.2)	156150-0-01			
		Needle Hole Plate C (φ2.2 cross-shaped groove)	156151-0-01			
		Needle Hole Plate D (φ2.5 cross-shaped groove)	156152-0-01			
		Needle Hole Plate E (φ2.6)	156153-0-01			
		Needle Hole Plate F (φ2.2)	156154-0-01			
J-18		Needle Plate S	152995-0-01			
		Needle Plate M	153423-0-01			
		Needle Plate L	153424-0-01			
J-20		Movable Knife Assembly A	152901-0-01			
		Movable Knife Assembly B	154176-0-01			
J-21		Thread Retainer A	152906-1-01			
		Thread Retainer B	154178-1-01			
		Thread Retainer C	154531-1-01			

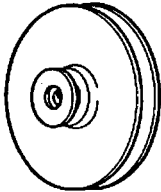
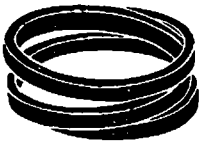
Ref. No.	Name of Parts	Sub-class	435		435-700	
			Standard	with Finger Guard & Eye Guard	Standard	with Finger Guard & Eye Guard
J-69		Spring B			155551-0-01	
K-33		Thread Take-up Spring (for standard)			145519-0-01	
		Thread Take-up Spring B (for thick materials)			144588-0-01	
K-37		Tension Spring (for standard)			104525-0-01	
		Tension Spring (for thick materials)			107606-0-01	
Z-10		Needle DB x 1 # 9 Assembly			100265-4-29	
		Needle DB x 1 #11 Assembly			100265-4-31	
		Needle DB x 1 #23 Assembly			100265-4-43	
		Needle DB x 1 #25 Assembly			100265-4-45	
		Needle DP x 5 # 9 Assembly			107415-4-09	
		Needle DP x 5 #11 Assembly			107415-4-11	
		Needle DP x 5 #14 Assembly			107415-4-14	
		Needle DP x 5 #16 Assembly			107415-4-16	
		Needle DP x 5 #18 Assembly			107415-4-18	
		Needle DP x 5 #19 Assembly			107415-4-19	
		Needle DP x 5 #21 Assembly			107415-4-21	
		Needle DP x 5 KN #10 Assembly			154763-4-10	
		Needle DP x 17 #14 Assembly			145646-4-14	
		Needle DP x 17 #16 Assembly			145646-4-16	
		Needle DP x 17 #18 Assembly			145646-4-18	
		Needle DP x 17 #19 Assembly			145646-4-19	
		Needle DP x 17 #21 Assembly			145646-4-21	
Needle DP x 17 #24 Assembly			145646-4-24			
Needle DP x 17 #25 Assembly			145646-4-25			
Needle PF x 34 R # 8 Assembly			148436-4-08			
Z-12		Bobbin (for standard)			145265-0-01	
		Bobbin B (for thick materials)			154663-0-01	

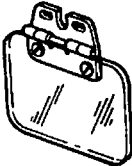
Ref. No.	Name of Parts	Sub-class	435		435-700	
			Standard	with Finger Guard & Eye Guard	Standard	with Finger Guard & Eye Guard
Z-13		Motor Pulley 1000/50 (φ14)	154306-0-01			
		Motor Pulley 1300/50 (φ14)	153428-0-01			
		Motor Pulley 1500/50 (φ14)	153426-0-01			
		Motor Pulley 1800/50 (φ14)	153109-0-01			
		Motor Pulley 1000/60 (φ14)	154305-0-01			
		Motor Pulley 1300/60 (φ14)	153427-0-01			
		Motor Pulley 1500/60 (φ14)	153425-0-01			
		Motor Pulley 1800/60 (φ14)	153108-0-01			
		Motor Pulley B 1300/50 (φ15.88)	153807-0-01			
		Motor Pulley B 1500/50 (φ15.88)	153805-0-01			
		Motor Pulley B 1800/50 (φ15.88)	153803-0-01			
		Motor Pulley B 1300/60 (φ15.88)	153806-0-01			
		Motor Pulley B 1500/60 (φ15.88)	153804-0-01			
		Motor Pulley B 1800/60 (φ15.88)	153802-0-01			
		Z-18		V Belt M49 1000/50	082104-9-90	
V Belt M49 1300/50	082104-9-90					
V Belt M50 1500/50	082105-0-90					
V Belt M51 1800/50	082105-1-90					
V Belt M48 1000/60	082104-8-90					
V Belt M49 1300/60	082104-9-90					
V Belt M49 1500/60	082104-9-90					
V Belt M50 1800/60	082105-0-90					
Z-27		Screw 3.57 x 5		009670-5-12		009670-5-12
Z-28		Eye Guard Assembly		153100-0-00		153100-0-00

INDEX

Parts No.	Ref. No.	Remark	Parts No.	Ref. No.	Remark	Parts No.	Ref. No.	Remark	Parts No.	Ref. No.	Remark
001401-4-16	Z-26- 3		014760-6-22	D-18- 2		025060-2-32	B-30		072600-3-60	D- 8	
003760-8-12	N-31			D-19			D-43		072600-7-60	C- 7	
009660-3-12	B-54			E- 1-17			E- 3		072630-2-60	B-26	
009660-7-12	B-57			E- 5- 8		025080-2-32	L-12		081003-6-70	B-46	
	C-19			F- 6		025100-1-32	L-22			B-49	
009670-4-12	G-28			F-26		025350-1-32	H- 3		081008-0-70	J-24	
	K- 8			F-35		025350-3-32	J- 2		082104-8-90	Z-17	
009670-5-12	C-60			G-19			M-19- 5			Z-18	
	H- 2			G-47		025680-1-33	C-35- 6		082104-9-90	Z-18	
	M- 8			H-25		025680-2-32	E-13		082105-0-90	Z-18	
	M-33			H-28		025770-2-32	A-36		082105-1-90	Z-18	
	M-41			H-37			H-10		100032-0-04	E-17	
	M-48			H-46			J-10			J-15	
	M-52			J-13		025800-3-33	C-67		100090-0-04	N-11	
	Z-27			J-40			L-25		100134-0-01	K-36	
009670-6-12	K- 4			J-55		028040-2-42	C-59		100136-0-01	K-24	
	K-14			J-61		028050-2-42	C-39			K-38	
	M-20			Z-14			D-36			K-39	
009670-7-12	K-44- 7		014770-6-22	B-13		028050-2-43	Z-15-11		100250-0-01	B-17	
	K-44-23			B-14		028060-2-42	D-52		100253-0-01	B- 7- 5	
009670-8-12	A- 7			B-48			D-54		100265-0-29	B- 1	
	M-19- 7			C- 2			G- 7		100265-0-31	B- 1	
009671-0-12	J- 1			G-22			L-28		100265-0-43	B- 1	
009671-4-12	M-19- 6		014821-0-22	C-43		028080-2-42	C-53		100265-0-45	B- 1	
009680-6-12	A-45			D-15			L-11		100265-4-29	Z-10	
	M- 2		017062-5-03	L-24		028100-2-42	L-23		100265-4-31	Z-10	
009680-7-12	K-44-20		017502-8-03	Z-15- 3		031452-2-03	Z-15-15		100265-4-43	Z-10	
009680-8-12	A-18			Z-15-16		046301-6-20	B-42- 2		100265-4-45	Z-10	
	A-22		017680-5-12	E- 9		046302-0-20	G-45- 1- 3		100315-0-02	A-34	
	B- 7- 1			E-12		047251-6-40	M-51		100360-0-03	J-17	
	M-21		017711-4-12	D-37		047501-2-42	A-15		100398-0-01	K-34	
009681-0-12	K-42		017761-4-12	B-31		048030-3-42	C-35- 1		100402-0-04	K-31	
	M-15			E- 2			H- 7		100887-0-01	Z-20	
009710-6-12	L-15		017762-0-12	N-28		048040-3-42	C- 1- 3		101572-1-01	Z- 9	
	N- 2		017762-2-02	D-49			C-30		101706-0-01	B-15	
	N-27		018060-8-22	D- 5- 2			G-45- 5			E- 1-28	
009710-7-12	A- 1		018061-4-22	G-57			G-54- 4		102538-0-07	Z-28- 1	
	K- 1		018061-6-22	D-53			H-11		102630-0-01	H-31	
	N- 7			G-44			H-19		102716-0-04	K-44- 2	
009711-4-12	A- 3		018062-0-22	G- 8			J- 8			K-44- 3	
	A-12			G-14			J-38		102843-0-04	B-29	
009761-4-12	A-11			G-53			J-51		103950-0-02	K-30	
	J-46		018062-2-22	G-42		048050-3-42	J- 9		104450-0-01	A-37	
	K-45		018063-0-22	F-20			J-35			A-41	
009781-4-12	B-10			G- 3			J-68		104525-0-01	K-37	
013710-7-12	G-31			G-26			K-44-16			K-40	
	G-33			G-37		048060-3-42	H-13		104567-0-01	M- 3	
	H- 5		018081-2-22	L-10			H-20			M-27	
013719-4-12	L- 5		018082-0-22	F- 5- 2			H-41		104567-0-01	M-29	
013760-6-12	H-24			F-33- 2		048080-3-42	B-61		104689-0-01	B-35	
	K- 7		018082-5-22	C-54		048100-1-42	L-19			C-69	
	L- 6		018500-8-22	E- 1-29		048110-1-42	C-27		105248-0-01	M-49	
013761-4-10	C-26		018501-2-22	E- 1- 9			D-33		105343-0-01	Z-34	
	D-27		018501-4-22	B-62			H-49		106030-0-01	L- 8	
013761-4-12	B-12		018681-0-22	J-36			J-64		106129-0-01	Z-28- 4	
	B-18		021060-1-02	L-29			N-18		106147-0-01	C-21	
014680-4-22	J- 6		021100-2-02	L-21		048120-1-42	J-52		107030-0-01	G-52- 3	
014680-6-22	B-36		021400-1-06	Z-26- 4		048150-1-42	B-23		107038-0-03	E- 1- 4	
	E- 1- 7		021500-1-03	Z-15- 6- 3		048160-1-42	D-16		107149-0-01	B-33	
	E- 1-19			Z-15-12		048170-1-42	D- 1		107153-0-02	H-21	
	F-15		021670-1-02	E- 1-23		048180-1-42	C-41			H-40	
	F-37		021670-2-02	M-19- 2			F-18		107231-0-02	D-10	
	H- 8		021680-2-02	C-35- 7			F-21		107415-0-09	B- 1	
	H-15			E- 1-11		048240-2-42	C- 9		107415-0-11	B- 1	
014760-6-22	B-38			N- 5		048320-2-42	L-13- 3		107415-0-14	B- 1	
	B-41		021800-1-03	C-68		048350-1-42	C- 6		107415-0-16	B- 1	
	B-44		025050-2-32	N- 8		048350-2-42	D- 7		107415-0-18	B- 1	
	B-51		025050-2-33	Z-15- 2		048620-2-42	C- 5		107415-0-19	B- 1	
	C-51		025060-1-32	D-51		071047-6-50	F- 3		107415-0-21	B- 1	
	D-12			J-47		071095-2-50	C-20		107415-4-09	Z-10	

Parts No.	Ref. No.	Remark	Parts No.	Ref. No.	Remark	Parts No.	Ref. No.	Remark	Parts No.	Ref. No.	Remark
107415-4-11	Z-10		141334-0-01	G-49		150172-0-01	Z-15- 5		151938-0-01	D- 4	
107415-4-14	Z-10			J-43		150173-0-01	Z-15- 6- 1		151939-0-01	G-54	
107415-4-16	Z-10		141472-0-02	D-21		150177-0-01	Z-15-13		151940-0-01	D- 5- 3	
107415-4-18	Z-10		141528-0-01	K-26		150179-0-01	Z-15- 7		151941-0-01	D- 5- 4	
107415-4-19	Z-10		141550-0-01	K-44-11		150180-0-00	Z-15-10		151944-0-01	D-18	
107415-4-21	Z-10		141583-0-01	H-43		150181-1-01	Z-15-14- 2		151946-0-00	C-10	
107606-0-01	K-37		141692-0-01	M-19- 4		150182-0-00	Z-15- 9		151947-1-01	D-18- 3	
107744-0-01	C-35- 3		141786-0-01	B-34		150184-0-01	Z-15- 4- 5		151948-0-01	D-18- 4	
107779-0-01	Z-19		141808-0-01	A-40		150189-0-01	Z-15-14- 1		151949-0-01	D-23	
107780-0-01	Z-21		141816-0-01	G-21		150192-0-01	Z-15- 4		151951-0-01	D-22	
108520-0-01	A-31		141860-0-01	L-13- 5		150202-0-01	Z-15- 6- 2		151952-0-01	D-14	
109239-0-02	A-48		142002-0-01	Z- 2		150553-0-01	D-44		151953-0-01	D-17	
109893-0-02	G- 6		142211-0-01	B- 8			G-51		151954-0-01	D-13	
110027-0-01	G-46		142443-0-01	Z- 7			J-59		151995-0-01	B-20	
110161-0-04	N-15		142566-0-01	K-44-13			N-29		151997-0-00	B-25	
	N-23		142628-0-01	C-28		150554-0-02	C-56		151998-0-00	B-27	
110168-0-01	E- 1-10			D-29		150555-0-01	D-25- 2		151999-0-01	B-28	
110251-0-01	C-23			H-48			H-42- 2		152000-0-01	B-19	
	D-45			J-63			H-44		152191-0-01	B-42	
	E- 1-22			N-17		150556-0-01	D-24		152231-0-00	B-16	
110495-0-03	B-47		142721-0-01	Z- 3			D-38		152232-0-01	B- 7	
110505-0-01	D-32		142990-0-01	Z-15- 4- 2		151163-0-01	C-48		152236-0-01	B- 7- 3	
111140-0-02	J-31		143591-0-01	E- 1-13			G-10		152237-0-01	B- 7- 7	
111865-0-01	D-20		144226-0-01	Z-29			N-25		152238-0-01	B- 7- 6	
	D-30		144458-0-01	B- 3		151601-0-01	K-44-14		152239-0-01	B- 7- 2	
	H-50		144588-0-01	K-33		151601-0-02	K-16		152240-0-01	B- 6	
	J-65		144694-0-01	M-12			N-21		152241-0-01	B- 6	
	N-19		144712-0-02	B-32- 1		151604-0-02	A-27		152242-0-01	B-11	
112468-0-01	J-67		145265-0-01	B-66		151886-0-01	C-45		152243-0-01	B- 5	
112751-0-03	K- 6			Z-12		151887-0-01	C-42		152244-0-00	B- 9	
113006-0-01	M-43		145318-0-01	E-15		151888-1-01	C-52		152245-0-01	B-39	
113316-0-01	K- 5		145446-0-01	K-18		151889-0-01	C-62		152246-0-01	B-40	
113431-0-02	C-35- 2			K-35		151890-0-00	C-63		152247-0-01	B-37	
	D-35			K-41		151891-0-01	C-65		152250-0-01	B-43	
114294-0-01	K-32		145478-0-01	E- 1-31		151892-0-01	C-64		152676-0-01	B-45	
114483-0-01	Z-23		145480-0-01	A-32		151893-0-01	C-61		152677-0-01	B-52	
114486-0-01	L-16		145519-0-01	K-33		151894-0-01	C-29		152678-0-01	B-50	
114985-0-01	A-44		145646-0-14	B- 1		151895-0-00	C-32		152679-0-01	B-53	
115003-0-01	C- 1- 6		145646-0-16	B- 1		151898-0-01	C-31		152680-0-01	B-55	
115012-0-02	C-55		145646-0-18	B- 1		151899-0-01	C-33		152681-1-01	B-63	
115018-0-01	C-66		145646-0-19	B- 1		151900-0-01	C-25		152682-0-01	B-65	
115077-0-03	K-27		145646-0-21	B- 1		151901-0-01	C-50		152683-0-01	B-60	
115138-0-01	K-44-18		145646-0-24	B- 1		151902-0-01	C-24		152684-0-01	B-59	
115157-0-01	Z- 6		145646-0-25	B- 1		151903-0-01	C-22		152685-0-01	B-64	
115493-0-02	A-49		145646-4-14	Z-10		151904-1-01	C-35		152686-0-01	B-65	
116016-0-01	Z-26- 2		145646-4-16	Z-10		151905-1-01	C-35- 5		152687-0-01	B-64	
116185-2-01	Z-26		145646-4-18	Z-10		151906-1-01	C-35- 4		152688-1-01	B-67	
116629-0-01	H-14		145646-4-19	Z-10		151907-0-01	C-34		152690-1-01	B-67	
116920-0-01	B-24		145646-4-21	Z-10			G-50		152693-0-01	C- 1- 5	
117150-0-01	M- 9		145646-4-24	Z-10		151907-0-01	J-58		152694-0-01	C- 1- 4	
	M-40		145646-4-25	Z-10		151908-0-01	C-36		152695-0-01	C- 4	
117363-0-01	C-40		146375-0-00	M-11		151910-0-01	C-38		152698-0-01	C-13	
117437-1-01	Z-26- 1		147111-0-01	C- 3		151912-0-01	D-26		152699-0-01	C- 8	
117934-0-01	A- 2		147151-0-00	G-16		151913-0-01	D-40		152700-0-00	C-12	
117936-0-01	A- 6		147476-0-01	N- 4		151914-0-01	D-39		152701-0-01	C-11	
118064-0-01	Z- 4		147487-0-01	Z- 5		151915-0-01	G-52		152702-0-01	C-16	
118719-0-01	A-33		147745-0-00	M-14- 4		151919-1-01	D-31		152703-0-00	C-15	
118837-0-01	Z- 8			M-35		151920-0-01	D-34		152704-0-00	C-14	
120068-0-01	N-20			M-44		151922-0-01	D-48		152705-0-01	C-17	
120448-0-01	K-44- 5		148133-0-01	E- 5- 2		151923-0-01	D-47		152706-0-01	C-18	
	Z-31		148436-0-08	B- 1		151924-0-01	D-46		152707-0-01	G-15	
122991-0-01	Z- 1		148436-4-08	Z-10		151925-0-01	D-28		152708-0-00	G-12	
126863-0-00	Z-15- 8		148735-0-01	M-23		151927-0-01	C-49		152709-0-00	G-11	
140208-0-01	H-18			M-37		151928-0-01	D-11		152710-0-01	G-13	
	J-39			M-55		151929-0-00	C-46		152711-0-00	G-20	
140392-0-01	A- 5		148921-0-00	M-32		151932-0-01	D- 9		152712-0-01	G-39	
140407-0-02	E- 1-30		149247-0-01	Z-16		151933-0-01	D- 5- 1		152713-0-01	G-18	
140423-0-00	M-14- 2		150106-0-01	Z-15- 6		151935-0-00	D- 5- 1- 1		152715-0-01	G-23	
	M-54		150139-0-01	Z-15-14		151936-0-01	D- 3		152718-0-01	F- 4	
140726-0-00	B-21		150150-0-01	Z-15		151937-0-01	D- 2		G-17		

Parts No.	Ref. No.	Remark	Parts No.	Ref. No.	Remark	Parts No.	Ref. No.	Remark	Parts No.	Ref. No.	Remark
152719-0-00	G-40		152857-0-01	L- 4		152949-0-01	M-14		153351-0-01	F-13	
152720-0-00	G- 4		152858-0-01	L- 3		152950-0-01	M-14- 1		153352-0-01	F-14	
152721-0-00	G-40		152859-0-01	L- 2		152951-0-01	M-14- 7			F-38	
152722-0-00	G- 4		152860-0-01	L- 1		152952-0-01	M-14- 5		153357-0-01	F-14	
152723-0-01	G-38		152861-1-01	L-17		152953-0-01	M-45			F-38	
152724-0-01	G- 1		152862-0-01	L-18		152955-0-01	M- 1- 2		153364-0-02	E- 1-18	
152725-0-00	F-19		152863-0-01	L-26		152956-0-01	M- 1- 3		153368-0-01	E- 1- 1	
	G- 2		152864-0-00	L-27			M- 4		153369-0-01	E- 1- 2	
	G-25		152865-0-01	L-20		152958-0-01	M- 1		153370-0-01	E- 1- 3	
	G-36		152866-0-01	L- 7		152959-0-01	M- 1- 1		153372-0-01	E- 1- 1	
152728-0-01	C-47		152867-0-00	A-26		152960-0-01	M- 6		153380-0-01	E- 5- 1	
	G- 9		152868-0-00	A-25		152961-0-01	M-19		153383-0-01	E- 8	
152729-0-01	G-24		152869-0-01	K- 2		152962-0-01	M- 5		153384-0-01	E- 7	
152730-0-01	G-35		152870-0-01	K- 3		152963-0-01	M-25		153391-0-01	E- 4	
152731-0-01	G-30		152872-0-01	K-29		152964-0-01	M-30		153392-0-01	E- 4	
152732-0-01	G-32		152873-0-01	K-28			M-31		153393-0-01	F- 2	
152733-0-01	G-27		152874-0-01	H-17		152965-0-01	M-26		153394-0-00	G-56	
152734-0-01	G-43		152875-0-01	K-17		152966-0-01	M-19- 1		153395-0-00	G-56	
152735-1-01	G-45		152876-0-01	K-15		152967-0-01	M-19- 3		153396-0-00	G-56	
152738-0-01	F-36- 2		152877-0-01	K-20		152968-0-01	F-40		153397-0-00	G-56	
152739-0-01	G-45- 3		152878-0-01	K-21			H-34		153398-0-00	G-56	
152744-0-01	H-30		152879-1-01	K-22		152969-0-01	M-34		153399-0-00	G-56	
152745-0-01	F- 7		152880-0-01	K-23			M-53		153400-0-00	G-56	
	F-34		152881-0-01	K-11		152971-0-01	M-58		153401-0-00	G-56	
152749-0-01	F-11		152883-0-00	K-10		152972-0-01	M-56		153402-0-00	G-56	
	F-31		152884-0-01	K- 9		152973-0-01	M-42		153403-0-02	E- 9	
152750-0-01	F-10		152886-0-01	J- 5			M-59		153404-0-00	G-56	
	F-30		152887-0-01	J- 7		152974-0-01	M-36		153405-0-00	G-56	
152755-0-01	F-16		152888-0-01	K-25		152976-0-01	C-58		153406-0-00	G-56	
152755-0-02	F-16		152889-0-01	K-13		152977-0-01	C-57		153407-0-00	G-55	
152755-0-03	F-16		152890-0-01	B- 2		152978-0-01	M-22		153408-0-00	G-55	
152756-0-01	C-44		152891-0-01	B- 4		152980-0-01	M-62		153409-0-00	G-55	
	F-17		152892-0-01	J-37			M-63		153410-0-00	G-55	
	F-22		152893-1-01	J-33		152981-0-01	J-29		153411-0-00	G-55	
	F-24		152896-0-01	J-34		152982-1-01	K-44		153412-0-00	G-55	
152760-0-01	F-25		152897-1-01	J-19		152983-0-01	K-44-17		153413-0-00	G-55	
152765-0-01	Z-22		152901-0-01	J-20		152984-0-01	K-44- 6		153414-0-00	G-55	
152788-0-00	E- 1-35		152904-0-01	J-26		152986-0-01	A-21		153415-0-00	G-55	
152794-0-01	H-33		152905-0-01	J-32		152988-0-01	J-11		153417-0-00	G-55	
152798-0-01	H-29		152906-1-01	J-21		152989-0-01	A-17		153418-0-00	G-55	
152799-0-01	H-26		152912-0-01	J-54		152992-0-01	M-10		153419-0-00	G-55	
152800-2-01	H-32		152913-0-01	G-54- 3		152995-0-01	J-18		153423-0-01	J-18	
152801-0-01	H-23			J-49		153040-0-01	B-32		153424-0-01	J-18	
152802-0-01	H-27		152914-0-01	G-34		153042-0-01	F-12		153425-0-01	Z-13	
152803-0-01	H-22			G-54- 2			F-32		153426-0-01	Z-13	
152805-0-01	H-38			J-50		153044-0-01	C- 1		153427-0-01	Z-13	
152806-0-01	H-39		152915-0-01	J-48		153046-0-01	H-51		153428-0-01	Z-13	
152808-1-01	D-25		152916-0-01	J-41		153049-0-01	K-12		153482-0-01	J-62	
	H-42		152917-0-01	J-53		153050-0-00	B-56		153528-0-01	M-16	
152811-0-01	H-45		152919-0-01	J-42		153058-0-01	C- 1- 2		153529-0-01	M-17	
152815-0-01	H-16		150920-0-01	J-57		153098-0-00	Z-28- 3		153530-0-01	M- 7	
152816-0-01	H-12		152921-0-01	J-56		153100-0-00	Z-28		153531-0-01	M-60	
152822-0-01	H- 9		152922-0-01	J-60		153102-0-01	Z-28- 2		153562-0-01	M-61	
152823-0-01	H- 6		152923-0-01	J-66		153104-0-01	G-41		153567-0-00	E- 1-33	
152827-0-01	H- 4		152924-0-01	H-47		153108-0-01	Z-13		153568-0-01	E- 1-34	
152828-0-01	H- 1		152925-1-01	J- 4		153109-0-01	Z-13		153569-0-01	E- 1-34	
152830-0-02	A-10		152926-0-01	J- 3		153138-0-01	K-19		153570-0-01	E- 1-32	
152831-0-00	A- 4		152929-0-01	J-12		153141-0-01	G-29		153571-0-01	E- 1-16	
152832-0-02	A- 4- 1		152933-0-01	K-44-10		153195-0-01	G-45- 4		153574-2-01	Z-30	
152833-0-01	A- 4- 2		152934-0-01	K-44- 1		153208-0-02	J-14		153596-0-01	J-23	
152834-0-02	A-13		152935-0-01	K-44-21		153219-0-01	J-27		153597-0-01	J-22	
152835-0-02	A-35		152936-0-01	K-44- 9		153220-0-01	J-30		153598-0-01	J-25	
152836-0-02	A-42		152937-0-01	K-44- 8		153222-0-01	J-28		153762-1-01	F- 5	
152838-0-01	A-46		152938-0-01	K-44-19		153312-0-00	G-40		153763-0-01	M-47	
152839-0-01	A-43		152939-0-01	K-44-12		153313-0-00	G- 4		153802-0-01	Z-13	
152841-0-02	A- 8		152940-0-01	K-44-22		153330-0-01	B- 7- 4		153803-0-01	Z-13	
152842-0-02	A-47		152941-0-01	K-44-15		153332-0-01	G-45- 1		153804-0-01	Z-13	
152847-0-00	A-24		152945-0-01	K-43		153346-0-01	B- 6		153805-0-01	Z-13	
152848-0-01	A-20		152948-0-01	M-13		153347-1-01	F- 1		153806-0-01	Z-13	
152852-1-01	L-13			M-50		153348-0-01	F-39		153807-0-01	Z-13	

Parts No.	Ref. No.	Remark	Parts No.	Ref. No.	Remark	Parts No.	Ref. No.	Remark	Parts No.	Ref. No.	Remark
153867-1-01	D- 6		154789-0-01	J-44							
153918-0-01	M-14- 6		155336-0-01	G-48							
153919-0-01	M-14- 3		155337-0-01	G-45- 2							
153920-0-01	M-46		155499-0-01	D-42							
	M-57		155500-0-01	D-50							
153921-0-01	M-39		155501-0-01	C-37							
153922-0-01	M-24		155523-0-01	D- 5							
	M-28		155551-0-01	J-69							
153924-0-01	M-38		156072-0-01	F-23							
153925-0-01	B-22		156073-0-01	E-16							
153926-0-01	E- 6		156074-0-01	E-18							
153927-0-01	M-18		156075-0-01	E- 5							
153931-0-01	N-24		156077-0-01	E- 5- 6							
153932-0-01	N-13		156080-0-00	E- 5- 7							
153933-0-01	N-16		156108-0-01	E- 5- 4							
153934-0-01	N-22		156109-0-01	E- 5- 5							
153935-0-01	N-14		156149-0-01	J-16							
153936-0-01	N-10		156150-0-01	J-16							
153937-0-01	N-12		156151-0-01	J-16							
153938-0-01	N- 3		156152-0-01	J-16							
153941-0-01	N- 1		156153-0-01	J-16							
	N-26		156154-0-01	J-16							
153942-0-01	N-30		156321-0-01	F-33							
153943-0-01	E- 1		156334-0-02	Z-25							
153944-0-01	E- 1-15		402887-0-01	B-58							
153945-0-01	E- 1-12										
153946-0-01	E- 1-21										
153947-0-01	E- 1-20										
153948-0-01	E- 1- 5										
153953-0-01	E- 1- 8										
153954-0-01	E- 1- 6										
153955-0-01	E- 1-26										
153956-0-01	E- 1-27										
153957-0-01	E- 1-24										
153958-0-01	N- 6										
153959-0-01	N- 9										
153960-0-02	A-19										
153961-0-01	E- 1-25										
153962-0-01	E- 1-14										
153972-0-01	E- 1										
153973-0-01	E- 1										
153974-0-01	E- 1										
154155-1-01	D-41										
154176-0-01	J-20										
154178-1-01	J-21										
154183-0-01	H-36										
154299-0-01	F-36										
154305-0-01	Z-13										
154306-0-01	Z-13										
154320-0-01	F-36										
154321-0-01	F-36										
154332-0-01	D-25- 3										
	H-42- 1										
154333-0-01	D-25- 1										
	H-42- 3										
154432-0-02	A-42										
154465-0-01	L-14										
154528-0-01	K-44- 4										
154531-1-01	J-21										
154663-0-01	B-66										
	Z-12										
154664-0-01	B- 2										
154702-0-01	Z-24										
154711-0-01	F- 5										
154738-0-01	L- 9										
154760-0-01	Z-32										
154763-0-10	B- 1										
154763-4-10	Z-10										
154785-0-00	A-14										
154788-0-01	J-45										



118-435
195435-1-02
September, 1981
Printed in Japan

From the library of: Superior Sewing Machine & Supply LLC